

1.0A Low Dropout Positive Voltage Regulator

IL1117-xx

The IL1117 is a series of low dropout voltage regulators which can provide up to 1A of output current. The IL1117 is available in eight fixed voltage, 1.2, 1.25, 1.5, 1.8, 2.5, 2.85, 3.3 and 5.0V. Additionally it is also available in adjustable version. On chip precision trimming adjusts the reference/ output voltage to within $\pm 2\%$. Current limit is also trimmed to ensure specified output current and controlled short-circuit current.

The IL1117 series is available in SOT-223, TO-252, TO-220 packages.

A minimum of 10uF tantalum capacitor is required at the output to improve the transient response and stability.

Features

- Dropout Voltage – 1.2V(Typ)
- Reference/Output Voltage Trimmed to $\pm 1\%$
- Maximum Input Voltage – 15V
- Adjustable Output Voltage or Fixed
1.2V, 1.25V, 1.5V, 1.8V, 2.5V, 2.85V, 3.3V, 5V
- Line Regulation typically at 0.2% max
- Load Regulation typically at 0.4% max
- Current Limiting and Thermal Protection
- Standard 3-Pin Power Packages
- Operating Junction Temperature Range
-40 to +125°C
(for IL1117-1.2V - 0 to +150°C)

Applications

- Post Regulator for switching DC/DC Converter
- High Efficiency Linear Regulator
- Battery Chargers
- PC Add on Card
- Motherboard clock supplies
- LCD Monitor
- Set-top Box

Absolute Maximum Ratings

Symbol	Description	Max	Units
VIN	Input Voltage	15	V
IOUT	DC Output Current	PD/(VIN-VO)	mA
TJ	Operating Junction Temperature Range	-40 to 125	°C
Θ_{JA}	Thermal Resistance (SOT-223)	150	°C/W
Θ_{JA}	Thermal Resistance (TO-252)	80	°C/W
Θ_{JA}	Thermal Resistance (TO-220)	60	°C/W
PD	Maximum Power Dissipation (SOT-223)	Internally Limited	mW
PD	Maximum Power Dissipation (TO-252)		mW
PD	Maximum Power Dissipation (SOT-220)		mW

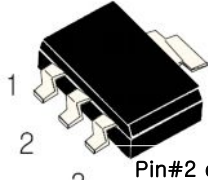
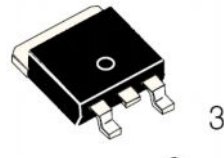
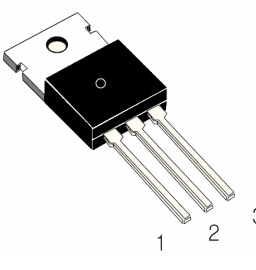
<p>SOT-223</p>  <p>Pin#2 connected with heat sink</p> <p>IL1117-xxET</p>	<p>TO-252</p>  <p>IL1117-xxD0T</p>
<p>TO-220</p>  <p>IL1117-xxKB</p>	<p>1. ADJ/GND 2. Output 3. Input</p>

Electrical Characteristics

Vin = 5V, Co = 10uF, Ta = 25°C, Tj = -40°C to +125°C (for IL1117-1.2 Tj = 0 to +150°C) unless otherwise specified

PARAMETER	CONDITIONS	MIN	TYP	MAX	UNIT
OUTPUT VOLTAGE					
IL1117-1.2 IL1117-1.25 (Adjustable) IL1117-1.5 IL1117-1.8 IL1117-2.5 IL1117-2.85 IL1117-3.3 IL1117-5.0	Io = 10mA to 1.0A, Vin = 2.7 to 12.0V Io = 10mA to 1.0A, Vin = 2.8 to 12.0V Io = 10mA to 1.0A, Vin = 3.0 to 12.0V Io = 10mA to 1.0A, Vin = 3.3 to 12.0V Io = 10mA to 1.0A, Vin = 4.0 to 12.0V Io = 10mA to 1.0A, Vin = 4.4 to 12.0V Io = 10mA to 1.0A, Vin = 4.8 to 12.0V Io = 10mA to 1.0A, Vin = 6.5 to 15.0V	1.176 1.225 1.470 1.764 2.450 2.790 3.240 4.900	1.200 1.250 1.500 1.800 2.500 2.850 3.300 5.000	1.224 1.280 1.530 1.836 2.550 2.910 3.360 5.100	V
LINE REGULATION					
IL1117-1.2 IL1117-1.25 (Adjustable) IL1117-1.5 IL1117-1.8 IL1117-2.5 IL1117-2.85 IL1117-3.3 IL1117-5.0	Io = 10mA, Vin = 2.7 to 12.0V Io = 10mA, Vin = 2.8 to 12.0V Io = 10mA, Vin = 3.0 to 12.0V Io = 10mA, Vin = 3.3 to 12.0V Io = 10mA, Vin = 4.0 to 12.0V Io = 10mA, Vin = 4.4 to 12.0V Io = 10mA, Vin = 4.8 to 12.0V Io = 10mA, Vin = 6.5 to 15.0V		2.0 0.1 2.0 2.0 2.0 2.0 3.0 4.0	7.0 0.2 7.0 7.0 7.0 7.0 7.0 10.0	mV % mV mV mV mV mV mV
LOAD REGULATION					
IL1117-1.2 IL1117-1.25 (Adjustable) IL1117-1.5 IL1117-1.8 IL1117-2.5 IL1117-2.85 IL1117-3.3 IL1117-5.0	Io = 10mA to 1.0A, Vin = 3.2V Io = 10mA to 1.0A, Vin = 3.3V Io = 10mA to 1.0A, Vin = 3.5V Io = 10mA to 1.0A, Vin = 3.8V Io = 10mA to 1.0A, Vin = 4.5V Io = 10mA to 1.0A, Vin = 4.85V Io = 10mA to 1.0A, Vin = 5.3V Io = 10mA to 1.0A, Vin = 7.0V		3.0 0.2 3.0 3.0 3.0 3.0 4.0 5.0	10.0 0.4 10.0 10.0 10.0 10.0 12.0 15.0	mV % mV mV mV mV mV mV
DROPOUT VOLTAGE (2)					
All Models	Io = 1A		1.20	1.30	V
	Io = 1A (Tj = -40°C to +125°C)		1.20	1.55	
CURRENT LIMIT	Vin - Vo = 5V	1000			mA
MINIMUM LOAD CURRENT					
Adjustable Models	Vin = 13.75V			5	mA
QUIESCENT CURRENT	Vin - Vo = 1.5V		5.2	10	mA
Adjust Pin Current	Io = 10mA, Vin - Vo = 1.4 to 10V		50	120	uA
vs Load Current, IL1117	Io = 10mA to 1A, Vin - Vo = 1.4 to 10V		0.5	5	uA
TEMPERATURE DRIFT	Tj = -40°C to +125°C		0.5		%
RMS Output Noise	Bandwidth of 10Hz to 10kHz at 25°C		0.003		%Vo
Ripple Rejection Ratio	120Hz input Ripple(Cadj for ADJ) = 25uF Vin -Vo = 5V, Io = 1.0A Tj = -40°C to +125°C	60	72		dB

NOTES: (1) IL1117-x adjustable versions require a minimum load current for ±3% regulation.

(2) Dropout voltage is the input voltage minus output voltage that produces a 1% decrease in output voltage.

Block Diagram

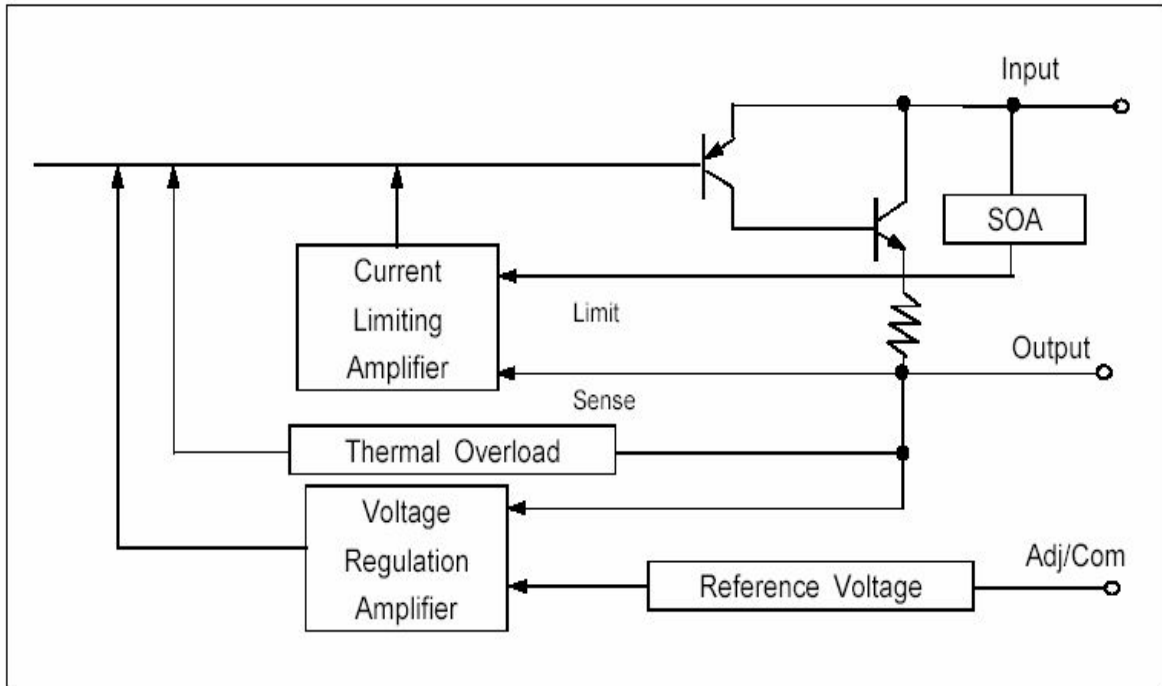

Application Information

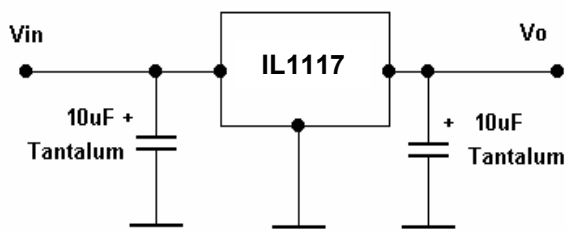

FIGURE 1. Fixed-Voltage Model
—Basic Connections.

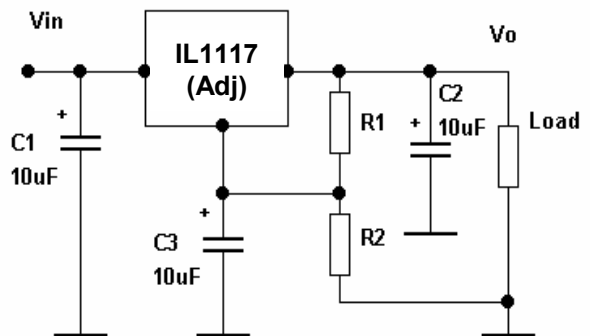
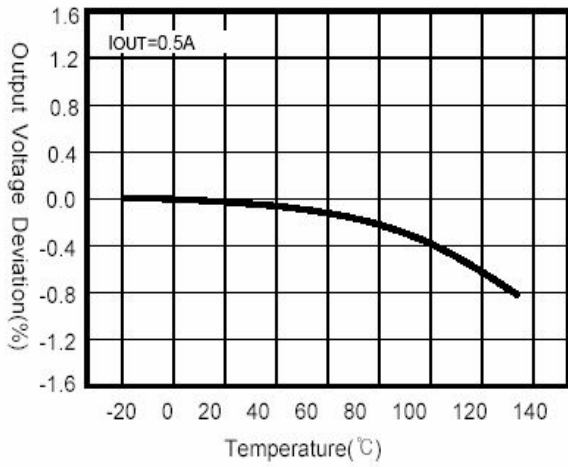

FIGURE 2. Adjustable-Voltage Model
--Basic Connections.

$$V_o = V_{ref}(1 + R_2/R_1) + I_{adj} * R_2$$

Typical Performance Characteristics

Temperature Stability



Ripple Rejection(with Cadj 25uF)

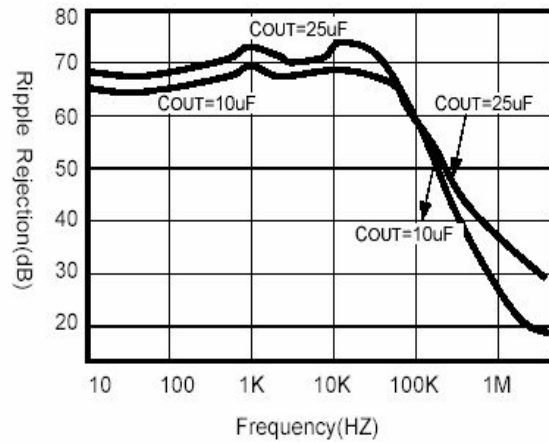

Minimum Load Current(Adjustable)

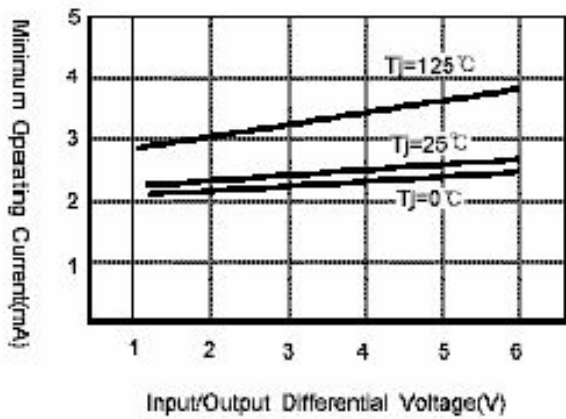

Adjust Pin Current

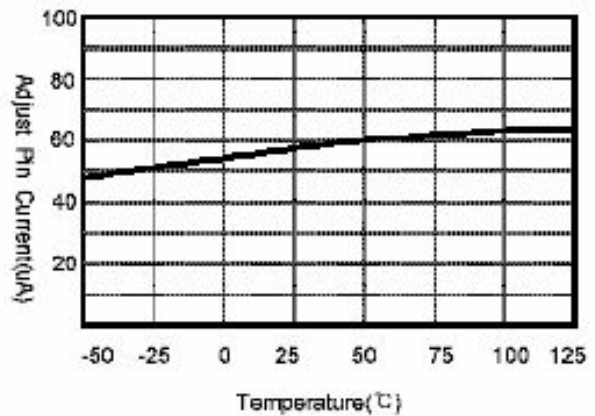

Dropout Voltage

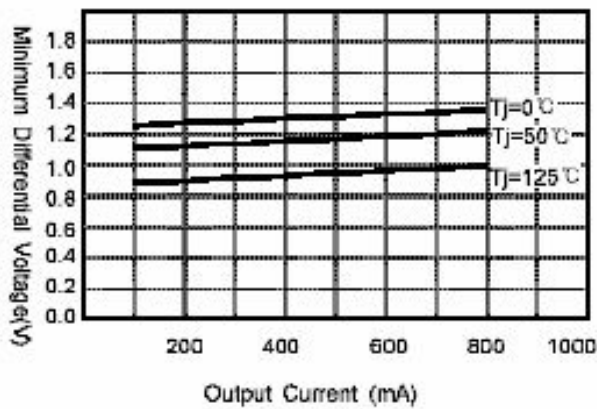

Dropout Voltage - Temperature

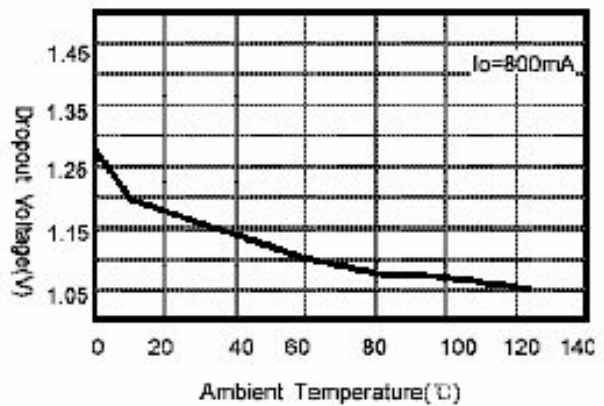

Typical Performance Characteristics (continue)

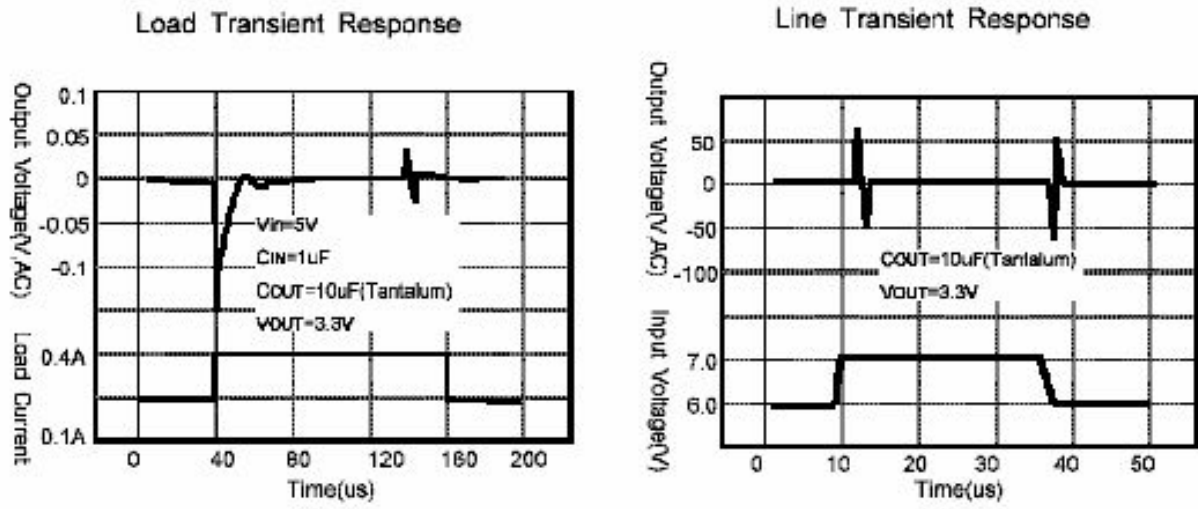

Figure 3.

Application Information

Output voltage adjustment

Like most regulators, the IL1117 regulates the output by comparing the output voltage to an internally generated reference voltage. On the adjustable version as shown in Fig.4, the V_{REF} is available externally as 1.25V between V_{OUT} and ADJ. The voltage ratio formed by R1 and R2 should be set to conduct 10mA (minimum output load).

The output voltage is given by the following equation:

$$V_{OUT} = V_{REF} \left(1 + \frac{R1}{R2}\right) + I_{ADJ} \times R2$$

On fixed versions of IL1117, the voltage divider is provided internally.

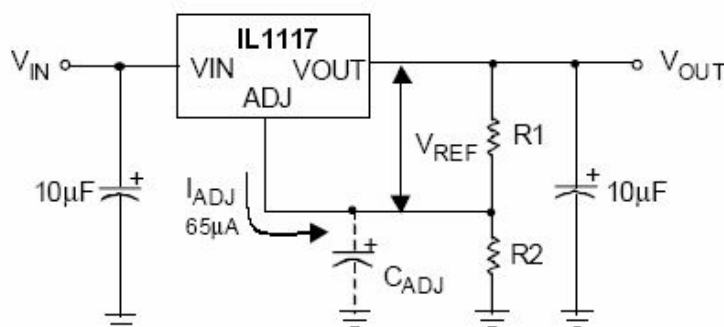

Figure 4. Basic Adjustable Regulator

Input Bypass Capacitor

An input capacitor is recommended. A 10µF tantalum on the input is a suitable input bypassing for almost all applications.

Adjust Terminal Bypass Capacitor

The adjust terminal can be bypassed to ground with a bypass capacitor (C_{ADJ}) to improve ripple rejection. This bypass capacitor prevents ripple from being amplified as the output voltage is increased. At any ripple frequency, the impedance of the C_{ADJ} should be less than R1 to prevent the ripple from being amplified:

$$(2\pi * f_{RIPPLE} * C_{ADJ}) < R1$$

The R1 is the resistor between the output and the adjust pin. Its value is normally in the range of 100- 200Ω. For example, with $R1 = 124\Omega$ and $f_{RIPPLE} = 120\text{Hz}$, the C_{ADJ} should be $> 11\mu\text{F}$.

Output Capacitor

IL1117 requires a capacitor from V_{OUT} to GND to provide compensation feedback to the internal gain stage. This is to ensure stability at the output terminal. Typically, a 10µF tantalum or 50µF aluminum electrolytic is sufficient.

Note: It is important that the ESR for this capacitor does not exceed 0.5 Ω.

The output capacitor does not have a theoretical upper limit and increasing its value will increase stability. $C_{OUT} = 100\mu\text{F}$ or more is typical for high current regulator design.

Load Regulation

When the adjustable regulator is used (Fig.5), the best load regulation is accomplished when the top of the resistor divider (R1) is connected directly to the output pin of the IL1117. When so connected, R_P is not multiplied by the divider ratio. For Fixed output version, the top of R1 is internally connected to the output and ground pins can be connected to low side of the load.

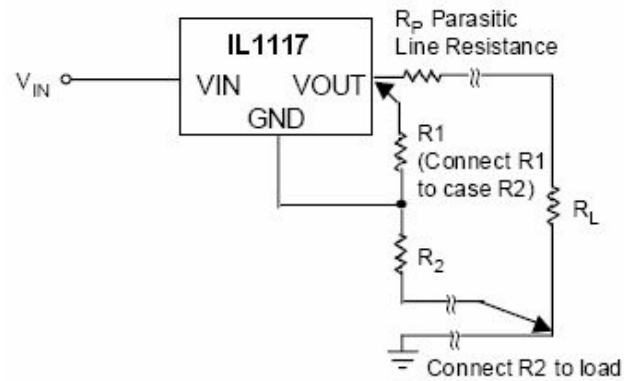

Figure 5. Best Load Regulation Using Adjustable Output Regulator

Thermal Protection

IL1117 has thermal protection which limits junction temperature to 150°C. However, device functionality is only guaranteed to a maximum junction temperature of +125°C. The power dissipation and junction temperature for IL1117 in DPAK package are given by

$$P_D = (V_{IN} - V_{OUT}) \times I_{OUT}$$

$$T_{JUNCTION} = T_{AMBIENT} + (P_D \times \theta_{JA})$$

Note: $T_{JUNCTION}$ must not exceed 125°C

Current Limit Protection

IL1117 is protected against overload conditions. Current protection is triggered at typically 1.6A.

Thermal Consideration

The IL1117 series contain thermal limiting circuitry designed to protect itself from over-temperature conditions. Even for normal load conditions, maximum junction temperature ratings must not be exceeded. As mention in thermal protection section, we need to consider all sources of thermal resistance between junction and ambient. It includes junction-to-case, case-to-heat-sink interface, and heat sink thermal resistance itself.

Junction-to-case thermal resistance is specified from the IC junction to the bottom of the case directly below the die. Proper mounting is required to ensure the best possible thermal flow from this area of the package to the heat sink. The case of all devices in this series is electrically connected to the output. Therefore, if the case of the device must be electrically isolated, a thermally conductive spacer is recommended.

SOT-223 PACKAGE OUTLINE DIMENSIONS

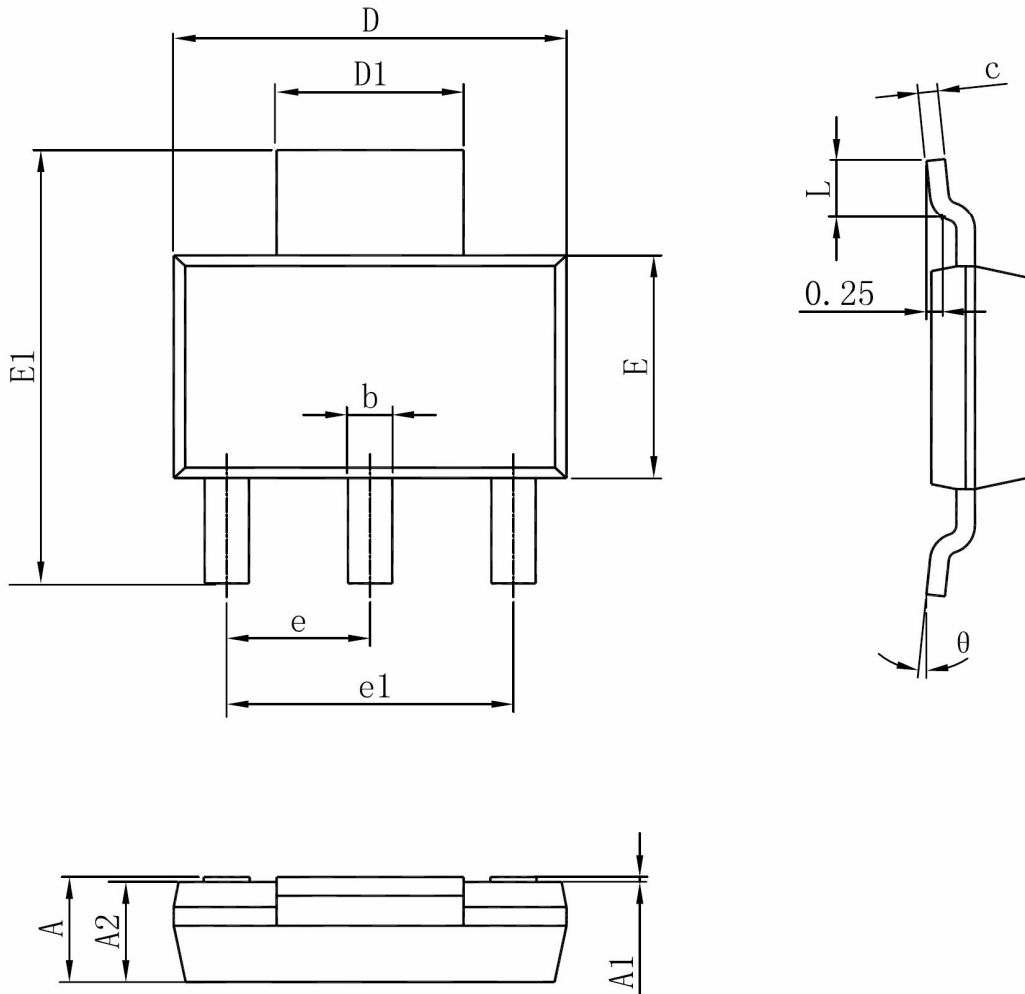

Symbol	Dimensions In Millimeters		Dimensions In Inches	
	Min	Max	Min	Max
A	1.520	1.800	0.060	0.071
A1	0.000	0.100	0.000	0.004
A2	1.500	1.700	0.059	0.067
b	0.660	0.820	0.026	0.032
c	0.250	0.350	0.010	0.014
D	6.200	6.400	0.244	0.252
D1	2.900	3.100	0.114	0.122
E	3.300	3.700	0.130	0.146
E1	6.830	7.070	0.269	0.278
e	2.300(BSC)		0.091(BSC)	
e1	4.500	4.700	0.177	0.185
L	0.900	1.150	0.035	0.045
θ	0°	10°	0°	10°

TO-220-3L PACKAGE OUTLINE DIMENSIONS

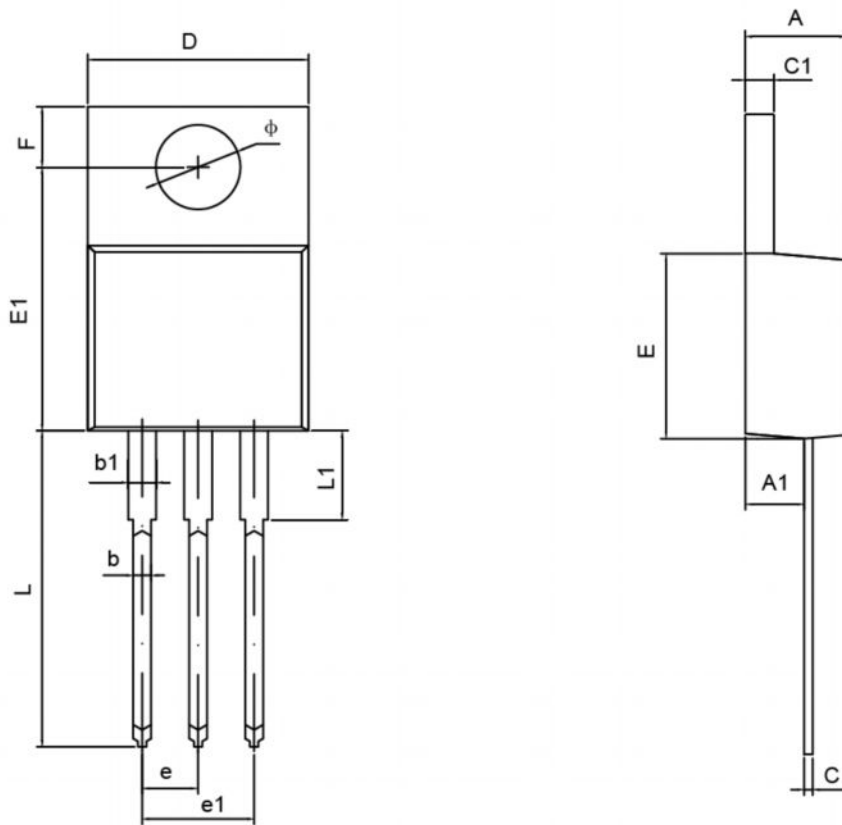

Symbol	Dimensions In Millimeters		Dimensions In Inches	
	Min	Max	Min	Max
A	4.470	4.670	1.176	0.184
A1	2.520	2.820	0.099	0.111
b	0.710	0.910	0.028	0.036
b1	1.170	1.370	0.046	0.054
c	0.310	0.530	0.012	0.021
c1	1.710	1.370	0.046	0.054
D	10.010	10.310	0.394	0.406
E	8.500	8.900	0.335	0.350
E1	12.060	12.460	0.475	0.491
e	2.540TYP		0.100TYP	
e1	4.980	5.180	0.196	0.204
F	2.590	2.890	0.102	0.114
L	13.400	13.800	0.528	0.543
L1	3.560	3.960	0.140	0.156
ϕ	3.790	3.890	0.149	0.153

TO-252-2L PACKAGE OUTLINE DIMENSIONS

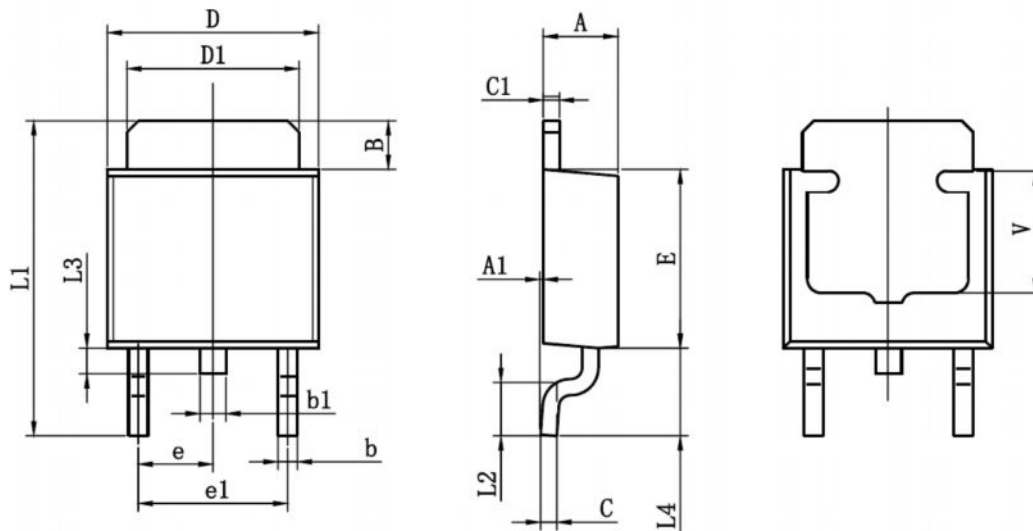

Symbol	Dimensions In Millimeters		Dimensions In Inches	
	Min	Max	Min	Max
A	2.200	2.400	0.087	0.094
A1	0.000	0.127	0.000	0.005
B	1.350	1.650	0.053	0.065
b	0.500	0.700	0.020	0.028
b1	0.700	0.900	0.028	0.035
c	0.430	0.580	0.017	0.023
c1	0.430	0.580	0.017	0.023
D	6.350	6.650	0.250	0.262
D1	5.200	5.400	0.205	0.213
E	5.400	5.700	0.213	0.224
e	2.300TYP		0.091TYP	
e1	4.500	4.700	0.177	0.185
L1	9.500	9.900	0.374	0.390
L2	1.400	1.780	0.055	0.070
L3	0.650	0.950	0.026	0.037
L4	2.550	2.900	0.100	0.114
V	3.80REF		0.150REF	