

**GEAR TACON LINE FOLLOW ROBOT**  
CODE 1108 LEVEL 2

This black line follow robot will check the different colour of ground. It is a sensor-activated robot which will run according to the infrared volume received by the sensor.

**Technical Specifications:**

- Power supply : 2 AA batteries (not included).
- Consumption : 150mA.
- Infrared detecting speed : controllable.
- PCB dimensions : 2.18 x 2.63 in.

**(1) ROBOT CONTROL CIRCUIT**

**How To Work:**

The circuit is composed of 2 major parts, light detecting and light flashing, as shown in Fig. 1.

The light detecting part is composed of 2 alike circuits that will work in the same manner. Each circuit will start working when the photo received infrared light from LED INF, causing voltage being passed through. The more reflected light will lessen the internal resistance and give bigger passing through voltage. Less reflected light will enlarge the internal resistance and give less passing through voltage.

When there is voltage being passed through the photo, it will cause TR6 and TR7 to work and force motor M1 to rotate. Moreover, this voltage will feed the light flashing part to work as well. Therefore, if any photo receives more light volume, the robot will move to the direction of that photo position. The VR1 and VR2 will work as a light detecting speed controller of each photo.

When the light flashing part received voltage, TR5 will start working and cause the light flashing set to work. TR3 and TR4 will be assembled as a multivibrator circuit and work

alternatively. When TR3 works, it will light up LED3. And when TR4 works, LED2 will be lit up. The flashing speed will be depended upon R7, R8, C1 and C2. R6 and R9 will reduce the current for LED2 and LED3. For LED1 will act as LED power and control the voltage of VR3 to be approximately 1.7 volts.

**Circuit Assembling:**

The PCB will be divided into two boards, FK1105-1 for circuit controlling and Body set for body, motor gear, wheel and battery holder assembling.

The FK1105-1 circuit assembling has been shown in Fig 2. It is recommended to assemble the circuit starting with a less height component i.e. diodes, resistor, electrolytic capacitors and transistors etc. Be careful while assembling and check for the matching of PCB poles and components before soldering as shown in Fig 3. For IDE port, press the pin of IDE port to be level with the black plastic before soldering as shown in Fig 4. Use a max. 40W solder and soldering tin with a tin and lead ratio of 60/40 together with a joint solution inside. Recheck the assembled circuit for your own confidence. Better use a lead sucker or a lead wire absorber in case of component misplacing to protect PCB from damage.

The Body set is to be assembled as shown in the next page.

**Testing:**

When the two circuit boards have been completely assembled, insert two AA batteries into the battery holder. Then adjust VR1, VR2 and VR3 to the middle point and slide switch SW to "on" position.

Lay down the assembled robot on the paper with black line. But if the robot is running out the black line, adjust VR1 to the left side a little bit and test again. In case of the robot is running out the black line to left side, adjust VR2 to the right side a little bit until the robot runs follow the line. But if the robot is running out the black line to right side, adjust VR3 to right side a little bit.

VR1 and VR2 will act as a infrared detecting speed controller of the photos. VR3 will act as a infrared transmit level controller of the infrared LED.

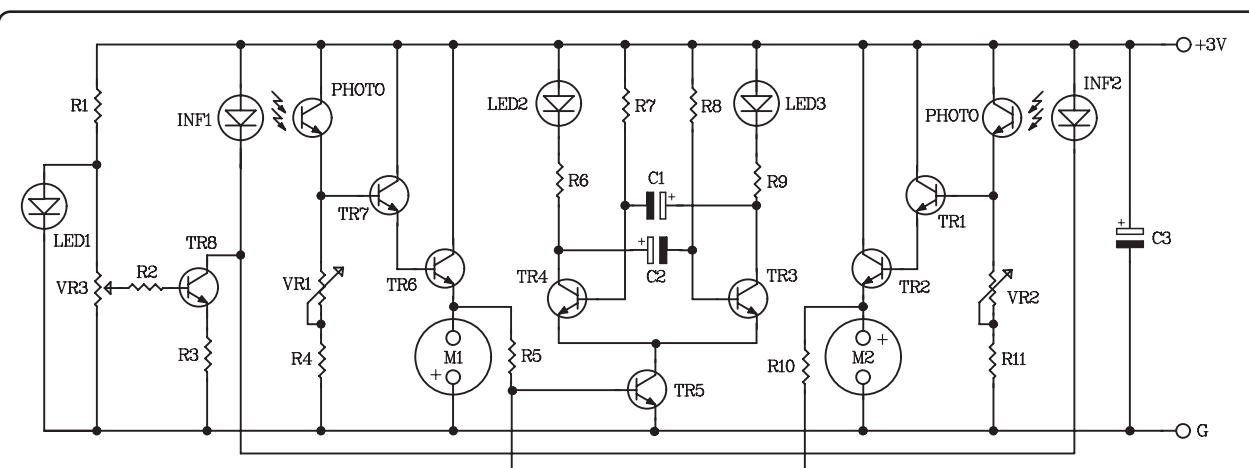

**Figure 2. TACON Line Follow Robot Circuit**

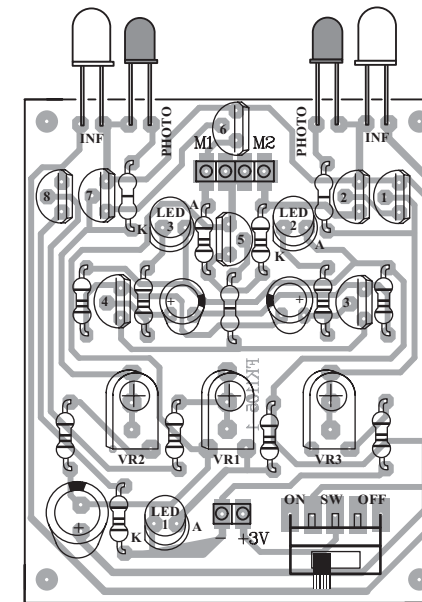

**FK1105-1**

**Figure 2. FK1105-1 Circuit Board Assembling**

**Figure 3. Components Installing**

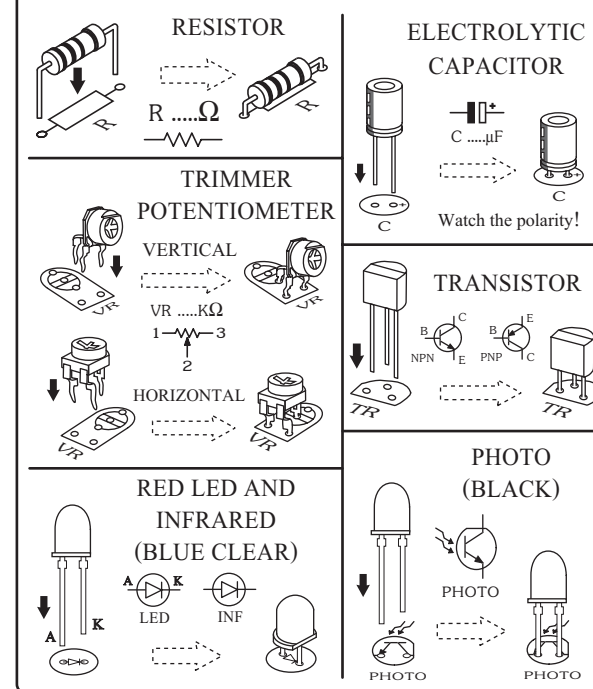

**Troubleshooting:**

As the circuit has only a few components, the main cause of troubles will come from component misplacing and defaulted soldering. When found out that the circuit does not work, check for the proper component placings and various soldering points.

**Figure 4. IDE Port Assembling To The FK1105-1 Circuit Board.**

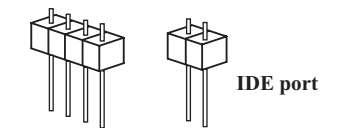

Press the pin of IDE port to be level with the black plastic.

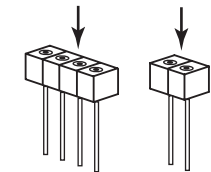

Install IDE port to PC-board and soldering.

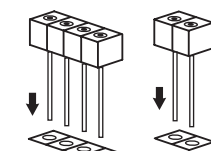

## (2) ROBOT BODY

### Assembling Steps of the Body set.

①

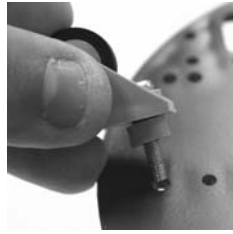

Mini Caster

Fix a mini caster wheel set to the Body set with using a 12 mm. bolt as a holder.

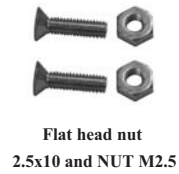

Flat head nut 2.5x10 and NUT M2.5

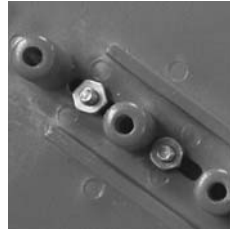

②

Install battery holder to body robot with flat head nut 2.5x10 and nut M2.5.



③

Insert the electric wire battery holder into body robot.

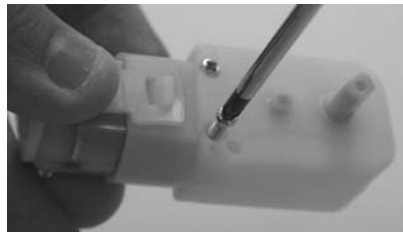

④

Take off the both screw of motor gear and then mount the motor lock. Secure with the both screw of motor gear.

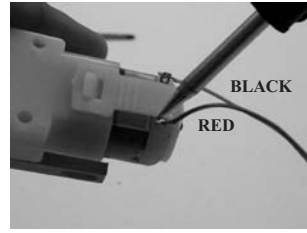

Solder electric wire at motor pole with red wire solders at left hand side and black wire solders at right hand side.

⑤

Solder motor wire to BR002-1 PC-board. Red wire is positive pole and black wire is negative pole. Character "L" is left motor gear and "R" is right motor gear.

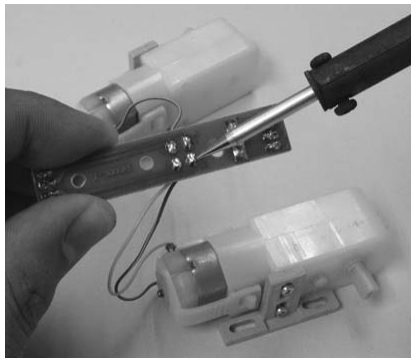

⑥

Mount motors, each with two #4 x 1/4" screws

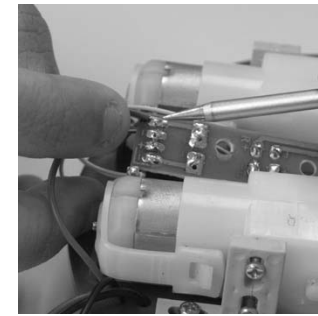
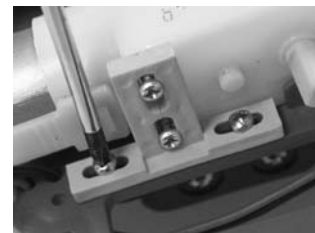

⑦

Solder battery holder wire to BR002-1 PC-board at B1 and B2. Red wire is positive pole and Black is negative pole.

⑧



Mount BR002-1 PC-board into body robot and secure them with two #2 x 1/4" screws.



Screw 2x1/4

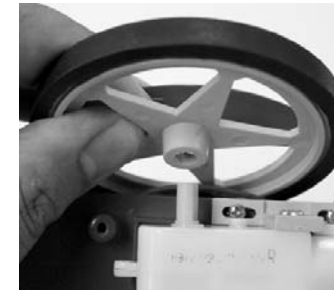

⑨

Install the wheels onto the shaft of the gear motors and secure them with the remaining two #4 x 1/4" pointy screws.



Screw 4x1/4

⑩

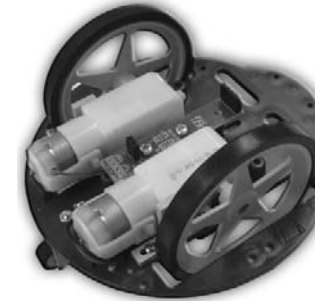

Body robot is completely installed.

⑪

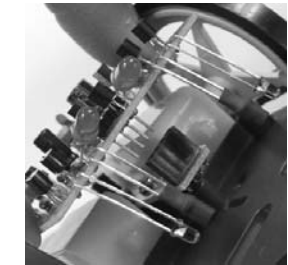

Install the control board into body robot.

⑫

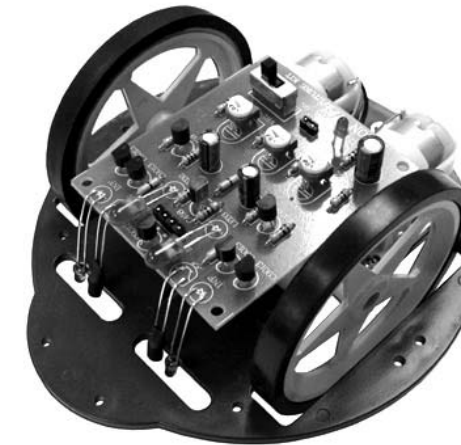

The robot is prompt working and playing.

NOTE: This robot has to playing at low light place for protect error working of sensor.



**BLACK LINE**  
**FOR TEST FK1108**