

LOUDNESS (STEREO)
CODE 654

LEVEL 2

This loudness circuit, it is circuit increases bass and twitter. Normal loudness is connected with volume by connecting at volume tap and adding switch as a loudness adjuster but it would not much increase the sound. This circuit has 3 frequency filters to increase bass and twitter.

Specification:

- Supply voltage : 12 VDC
- Consumption : 5mA.max
- Dimension : 2.22 x 3.33 inches.

How it works:

The following instruction is used both for L and R. Input signal is connected through 3 frequency filters, C7, R7 to the base of TR1 to amplifying signal. The amplifying signal will be sent through C9 and coupling to OUTPUT point.

PCB assembly:

Shown in Figure 3 is the assembled PCB. Starting with the lowest height components first, taking care not to short any tracks or touch the edge connector with solder. Some tracks run under components, and care should be taken not to short out these tracks. If the pins will not enter the holes with ease, use a small drill to slightly enlarge the opening. All components with axial leads should be carefully bent to fit the position on the PCB and then soldered into place. Make sure that the electrolytic capacitors are inserted the correct way around. Some components are particularly sensitive to heat (ie: Transistors, IC's, diodes etc.) extra care must be taken to only apply the iron for as little time as possible, using a pair of pliers to grip the leads will help

conduct heat away. Trim components leads with wire cutters to prevent excess lengths causing a short circuit. Now check that you really did mount them all the right way round!

Testing:

Connect this circuit prior to tone-control or EQ. Giving power supply by connecting +12V at position pole, G at negative pole. Increasing volume, base and twitter from speaker will be increased.

Application: Installation according to the figure.

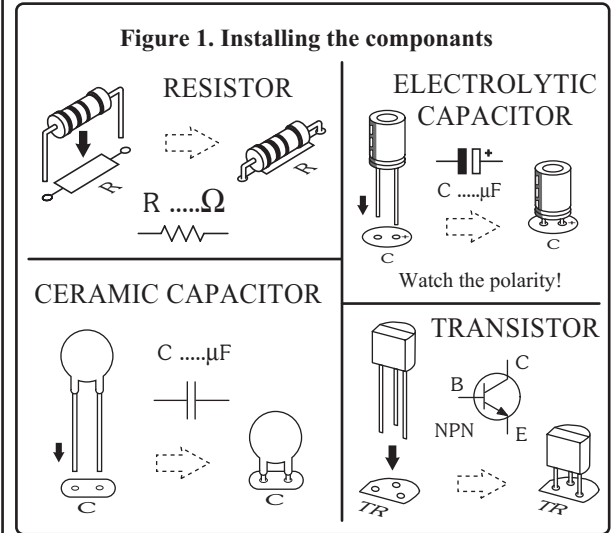

Troubleshooting:

The most problem like the fault soldering. Check all the soldering joint suspicious. If you discover the short track or the short soldering joint, re-solder at that point and check other the soldering joint. Check the position of all component on the PCB. See that there are no components missing or inserted in the wrong places. Make sure that all the polarised components have been soldered the right way round.

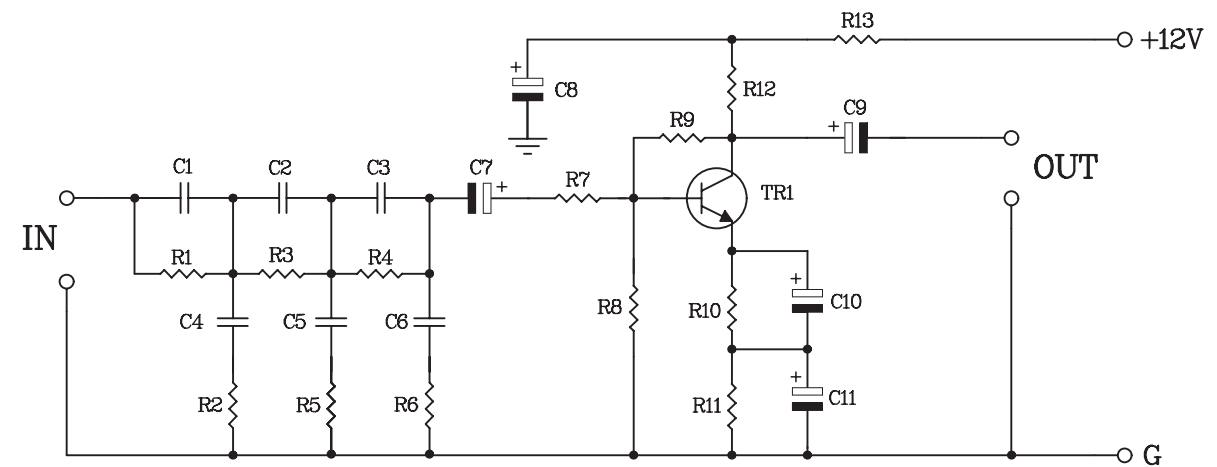

Figure 2. The loudness (stereo) circuit

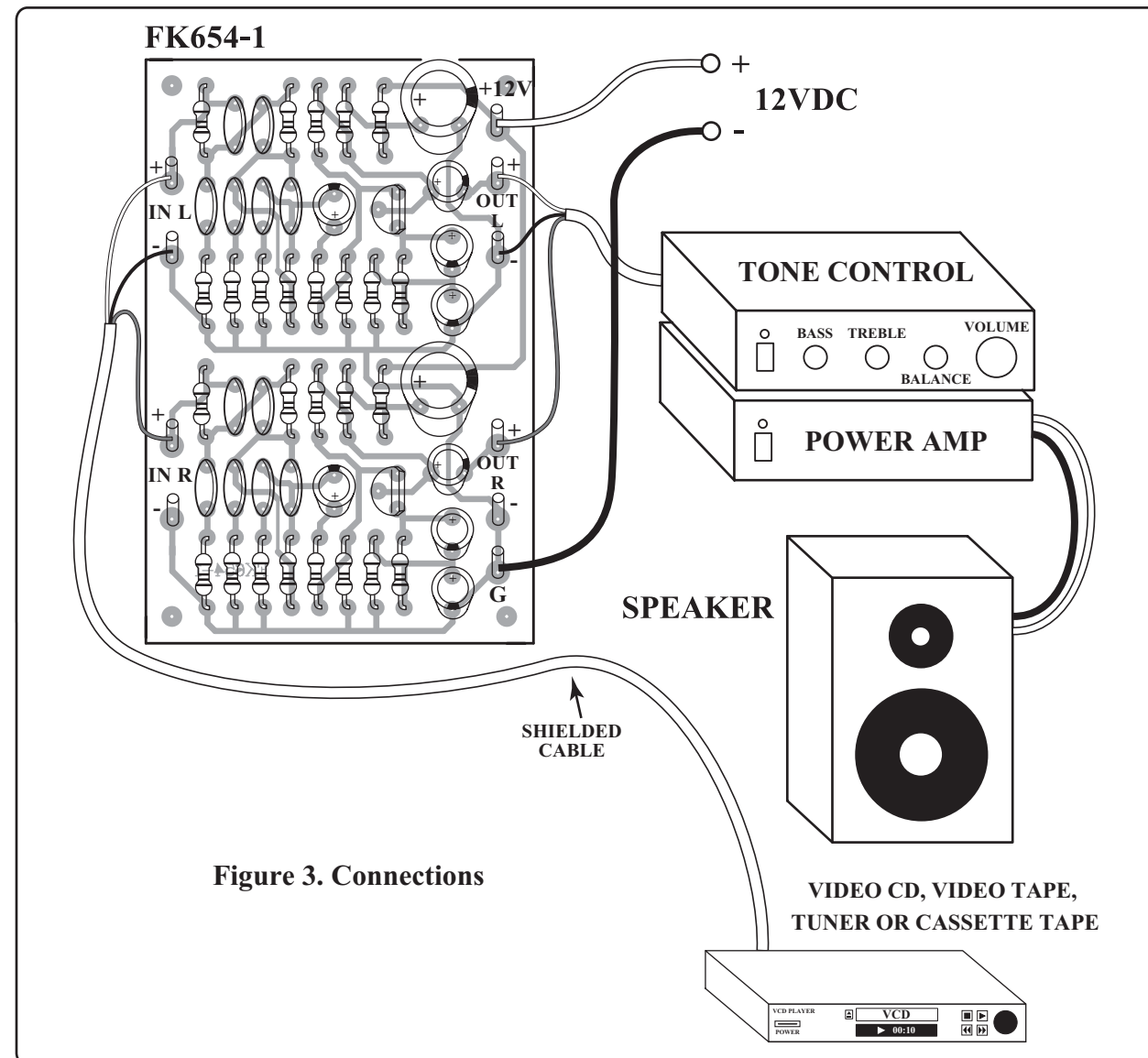

Figure 3. Connections