

POWER AMP. OTL 30+30W R1%
CODE 657 **LEVEL 3**

This amplifier circuit contains only main amplifier. There is no tone and control. The circuit is OTL so no problem regarding speaker concern when output of transistor is shorted.

Specification:

- Power supply : 50VDC max. / more then 3A.
- Output power : 30Wrms @ 4 or 8Ω
- Dimension : 4.65 x 1.77 inches.

How it works:

Hereunder explanation is applied for both left and right sides due for both have the same function. Signal from INPUT will pass R19, C10 to TR1 which incharges for amplifying signal. The amplified signal is transferred to C8 and TR2 as a predrive, then transferred to TR3 and TR4 which is the driver that send the signal next to TR5 and TR6 for re-amplifying through C2 to coupling the signal towards speaker C3. R20 will then feedback the signal to TR1 for amplifying control. R1 and R2 incharge for high frequency oscillating prevention.

PCB assembly:

Shown in Figure 3 is the assembled PCB. Starting with the lowest height components first, taking care not to short any tracks or touch the edge connector with solder. Some tracks run under components, and care should be taken not to short out these tracks. If the pins will not enter the holes with ease, use a small drill to slightly enlarge the opening. All components with axial leads should be carefully bent to fit the position on the PCB and then soldered into place. Make sure that the electrolytic capacitors are inserted the correct way around. Some components are particularly sensitive to heat (ie: Transistors, IC's, diodes etc.) extra care must be taken to only apply the iron for as little time as possible, using a pair of pliers to grip the leads will help conduct heat away. Trim components leads with wire cutters to prevent excess lengths causing a short circuit. Now check that you really did mount them all the right way round!

*** Screwing heatsink to transistor TR5, TR6 before combining to print at PCB. Tightly screwing both device together before soldering.

Testing:

Connecting SP with L&R loudspeakers and IN L,R with tape or cassette signal. Connecting +50V and G with power supply. Decreasing signal to zero and then respective increasing.

The sound from IN will then amplified toward the loudspeaker. If there is on sound from the loudspeaker or burst smell, plug out and immediately check the circuit.

Application:

12V OUT transfers the voltage to tone and control part in order to amplify to 30W. This set requires tone-control stereo code 626.

Figure 1. Installing the componants

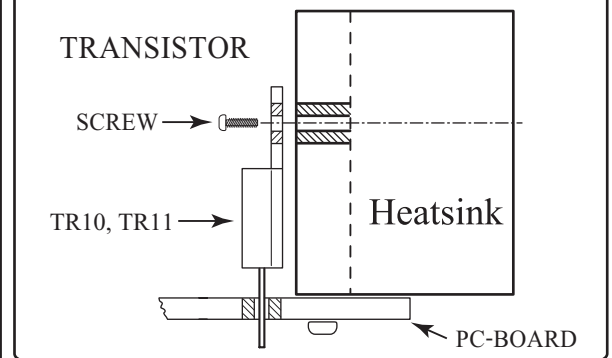
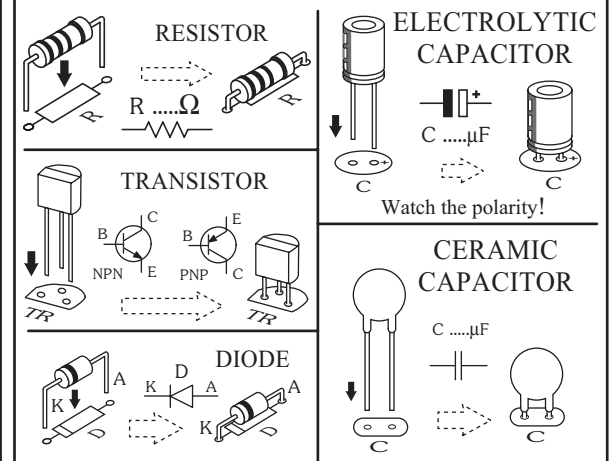

Troubleshooting:

The most problem like the fault soldering. Check all the soldering joint suspicious. If you discover the short track or the short soldering joint, re-solder at that point and check other the soldering joint. Check the position of all component on the PCB. See that there are no components missing or inserted in the wrong places. Make sure that all the polarised components have been soldered the right way round.

Figure 2. The power amp OTL 30W R1% circuit

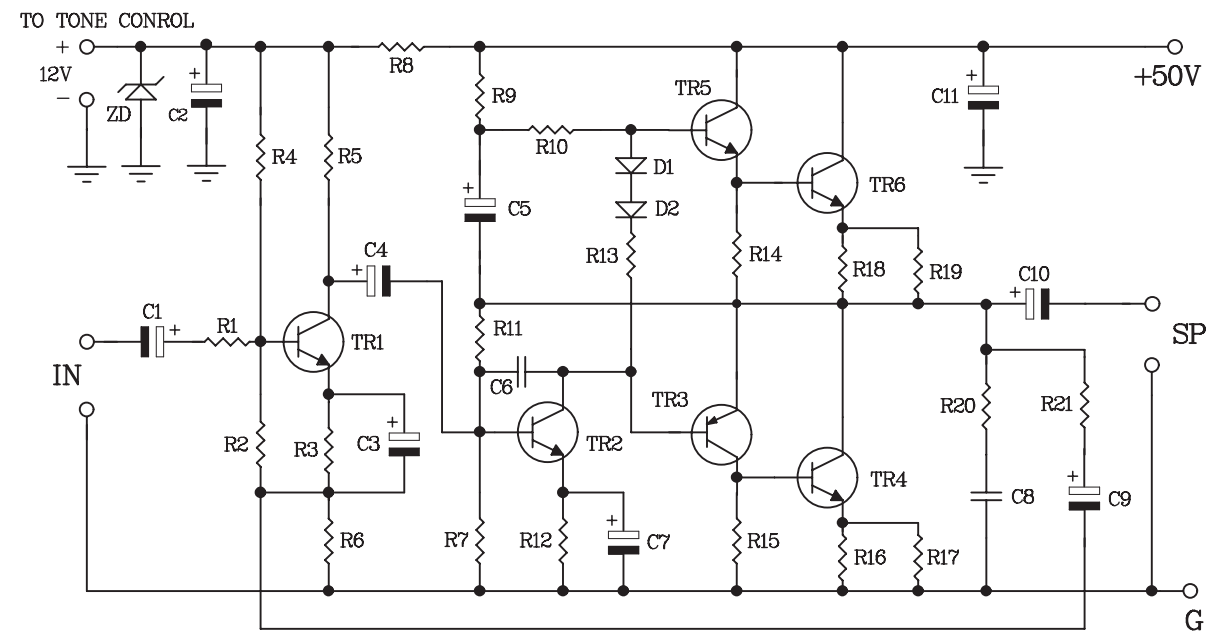

Figure 3. Connections

