

POWER AMP. OCL 35W R1%
CODE 658 LEVEL 3

This circuit is the main amplifier which using a circuit the end stage is always set to class AB.

Specification:

- Power supply : +35VDC and -35VDC max. / more than 2A.
- Frequency response : 10 to 100 KHz (± 1dB)
- Input sensitivity : 1Vrms. - Input impedance : 15KΩ
- Output power : 35Wrms class AB @ 4 or 8Ω
- Total harmonic distortion : 0.02%
- Dimension : 4.74 x 2.28 inches.

How it works:

TR1 and TR2 are used to differential amplifier circuit of signal. TR3 is used to pre-drive of signal. TR8 and TR9 drive of signal. TR10 and TR11 output amplifier. TR4 limits the current. TR5 and TR1 are setting the bias for inert current. TR6 and TR7 protect TR10 and TR11 from over current supply. This circuit designs work to the direct coupling. The input signal is fed to the base of TR1 through C1 and R28, which TR1 amplifier the signal with have TR2 control amplifier. The gain ratio is R10 divided by R5. The signal of the collector of TR1 is connected in the base of TR3. The signal from TR3 is fed to TR8 and TR10 amplifies of positive signal. TR9 and TR10 amplifies of negative signal. This amplifier of signal is supply 35 to 40W into the 8Ω speaker.

PCB assembly:

Shown in Figure 3 is the assembled PCB. Starting with the lowest height components first, taking care not to short any tracks or touch the edge connector with solder. Some tracks run under components, and care should be taken not to short out these tracks. If the pins will not enter the holes with ease, use a small drill to slightly enlarge the opening. All components with axial leads should be carefully bent to fit the position on the PCB and then soldered into place. Make sure that the electrolytic capacitors are inserted the correct way around. Some components are particularly sensitive to heat (ie: Transistors, IC's, diodes etc.) extra care must be taken to only apply the iron for as little time as possible, using a pair of pliers to grip the leads will help conduct heat away. Trim components leads with wire cutters to prevent excess lengths causing a short circuit. Now check that you really did mount them all the right way round!

Testing:

The circuit is powered from a dual 35 volts power supply. Adjusting VR1 to the center, shorting input to ground and connect the supply to circuit. Disconnect the power supply if there is burst smelling. Measure the voltage at "SP" point, should lesser then 0.5V. Under normal condition, connect the loudspeaker with "SP" point and input signal, then increasing the signal and listening the feedback. In case to

adjust inert current, disconnect the power supply, loudspeaker and jump input to ground. Take off the collector of TR10. Connect a multimeter set to read DC current at "+35V" point and the collector of TR10. Connect the power supply to circuit. Adjust VR1 until the current read on the multimeter is 40mA, then disconnect the power supply and reinstalling. If it is 35 to 40W MONO circuit, it is need transformer rate 2A. and super tone control mono circuit.

Figure 1. Installing the components

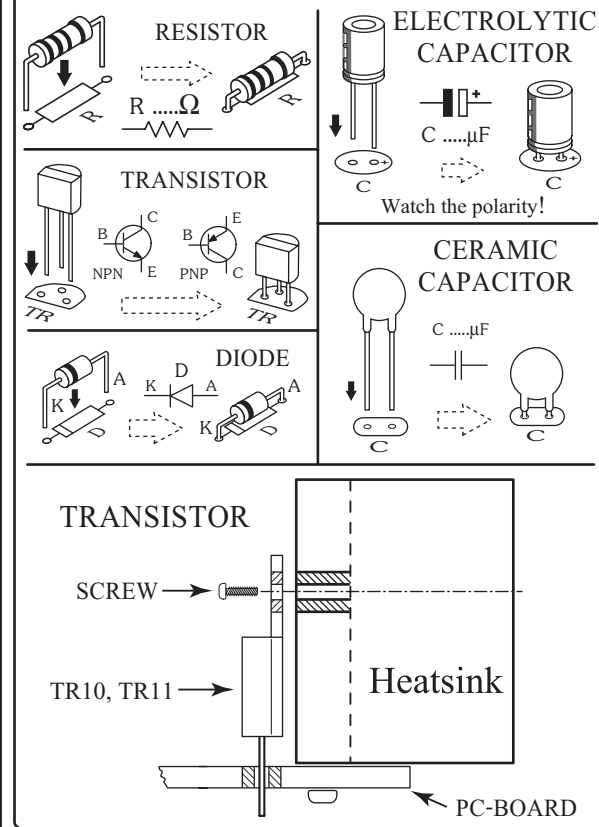

Troubleshooting:

The most problem like the fault soldering. Check all the soldering joint suspicious. If you discover the short track or the short soldering joint, re-solder at that point and check other the soldering joint. Check the position of all component on the PCB. See that there are no components missing or inserted in the wrong places. Make sure that all the polarised components have been soldered the right way round.

Figure 2. The power amp OCL 35W R1% circuit

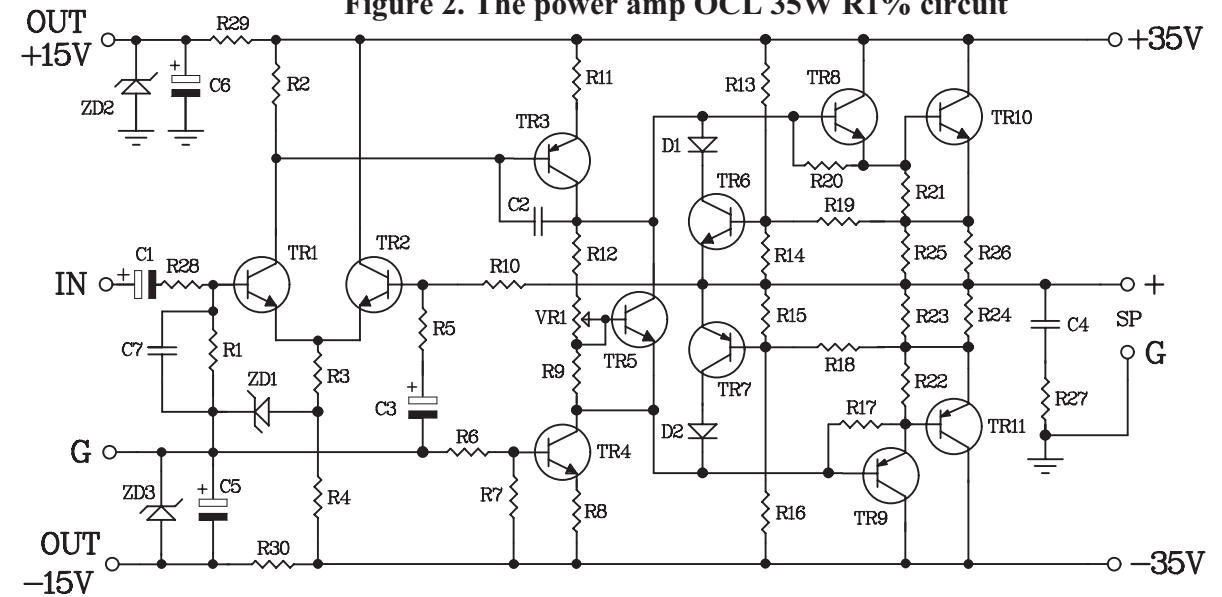

Figure 3. Connections

