

POWER AMP. OCL 100+100W R1%
CODE 667 **LEVEL 3**

This circuit is the main amplifier which using a circuit the end stage is always set to class AB.

Specification:

- Power supply : +50VDC and -50VDC max. / more then 6A.
- Frequency response : 10 to 100 KHz (± 1dB)
- Input sensitivity : 1Vrms.
- Input impedance : 20KΩ
- Output power : 100Wrms class AB @ 4 or 8Ω
- Total harmonic distortion : 0.02%
- Dimension : 5.86 x 2.39 inches.

How it works:

TR1 and TR2 are used to the first part differential amplifier circuit of signal. TR4 and TR5 are used to the second part differential amplifier circuit of signal. TR3 is used to limit the current for TR1 and TR2. TR9 is used to the collector load circuit for TR4 and TR5 with fed to R8. TR8 is setting the bias for inert current. TR6 and TR7 protect TR11 and TR13 from over current supply. This circuit designs work to the direct coupling. The input signal is fed to the base of TR1 through C1, which TR1 amplifies the signal with have TR2 control amplifier. After the signal to amplifier again with TR4. The signal of the collector of TR5 is fed to TR10 and TR11 amplifies of positive signal. TR12 and TR13 amplifies of negative signal. This amplifier of signal is supply 100W into the 8Ω speaker.

PCB assembly:

Shown in Figure 3 is the assembled PCB. Starting with the lowest height components first, taking care not to short any tracks or touch the edge connector with solder. Some tracks run under components, and care should be taken not to short out these tracks. If the pins will not enter the holes with ease, use a small drill to slightly enlarge the opening. All components with axial leads should be carefully bent to fit the position on the PCB and then soldered into place. Make sure that the electrolytic capacitors are inserted the correct way around. Some components are particularly sensitive to heat (ie: Transistors, IC's, diodes etc.) extra care must be taken to only apply the iron for as little time as possible, using a pair of pliers to grip the leads will help conduct heat away. Trim components leads with wire cutters to prevent excess lengths causing a short circuit. Now check that you really did mount them all the right way round!

Testing:

The circuit is powered from a dual 50 volts power supply. Adjusting VR1 counterclockwise and connect the supply to circuit. Disconnect the power supply if there is burst smelling. Measure the voltage at "SP" point, should lesser then ± 30mV. In case to adjust inert current, disconnect the power supply, loudspeaker and jump input to ground. Connect a multimeter set to read DC current at "+50V" point. Connect the power supply to circuit. Adjust VR1 until the current read on the multimeter is 25mA, then disconnect the power supply and reinstalling. If it is 100W STEREO circuit, it is need transformer rate 6A.

Figure 1. Installing the components

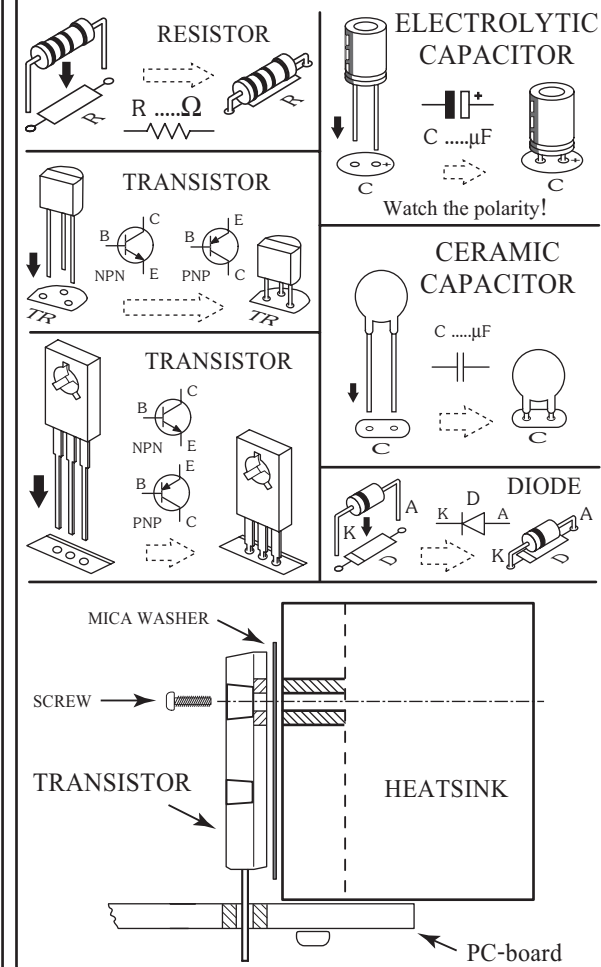

Troubleshooting:

The most problem like the fault soldering. Check all the soldering joint suspicious. If you discover the short track or the short soldering joint, re-solder at that point and check other the soldering joint. Check the position of all component on the PCB. See that there are no components missing or inserted in the wrong places. Make sure that all the polarised components have been soldered the right way round.

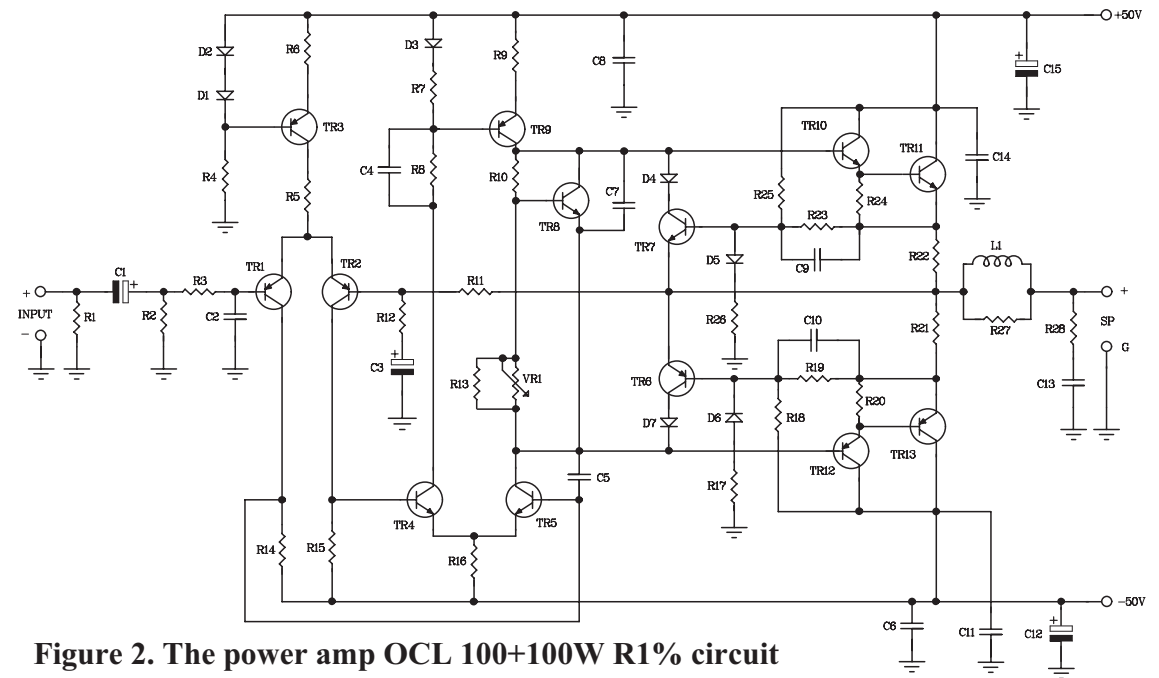

Figure 2. The power amp OCL 100+100W R1% circuit

