

# Connection diagram of the 12V or 24VDC to 220VAC convertor

K3501

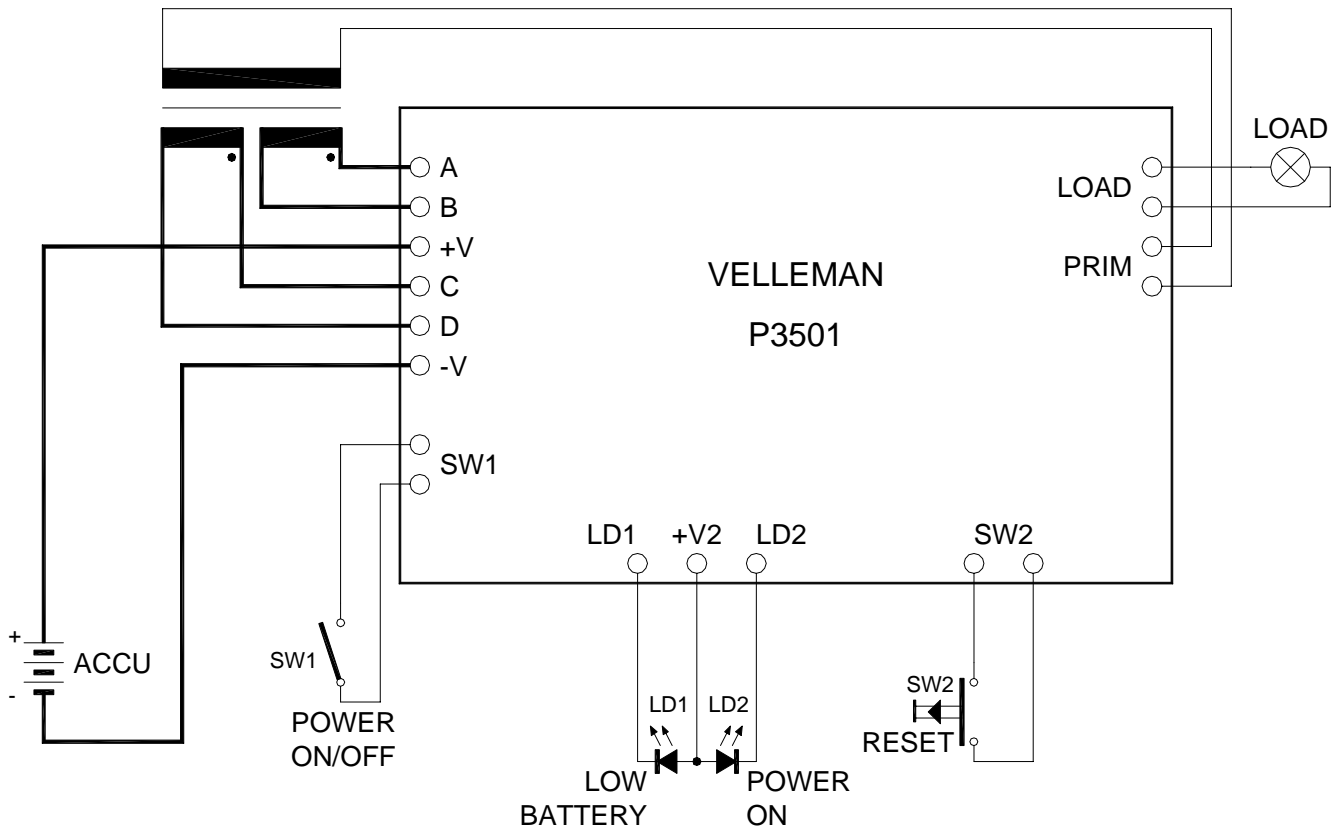

# Connection diagram of the 12V or 24VDC to 220VAC convertor with protection against polarity reverse.

K3501

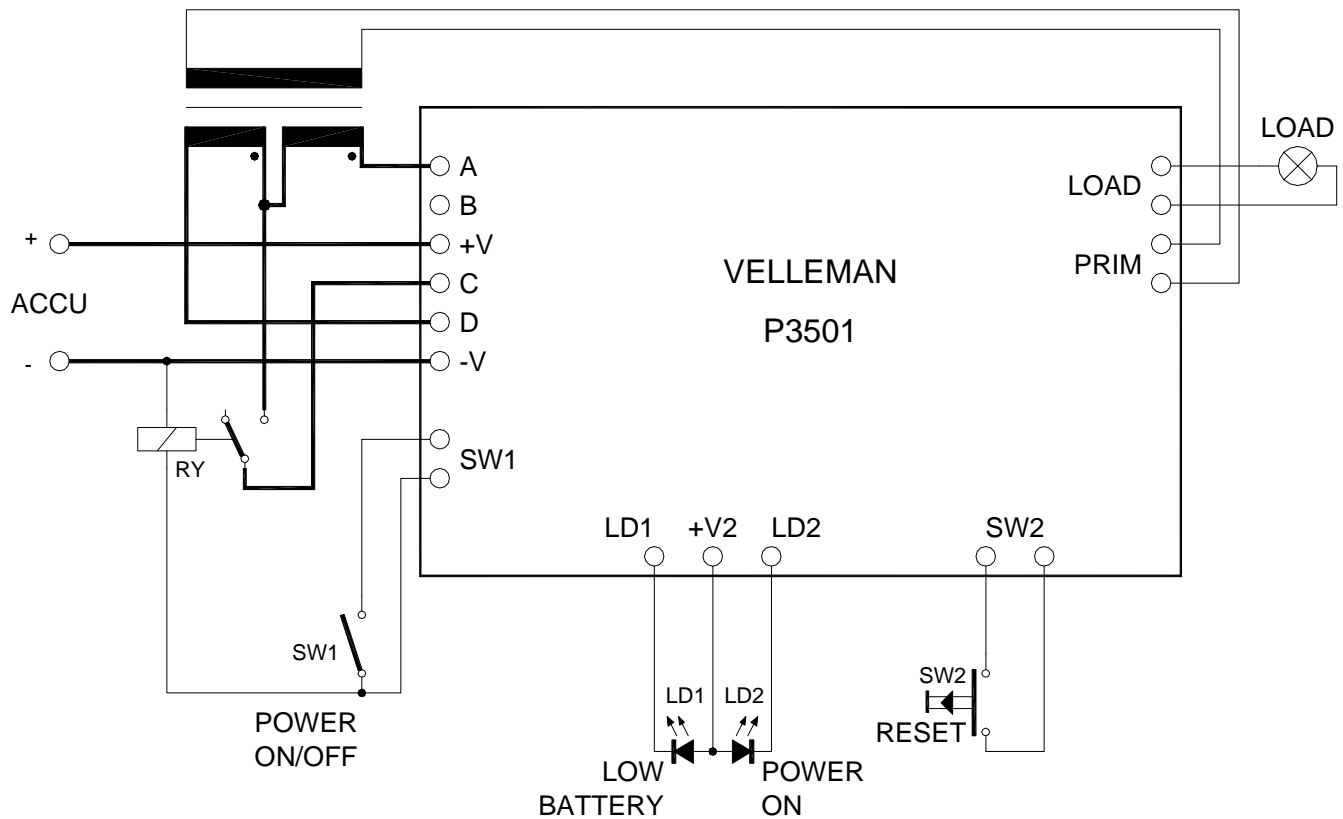

# Codelock receiver working together with the car alarm (K3501)

K6707

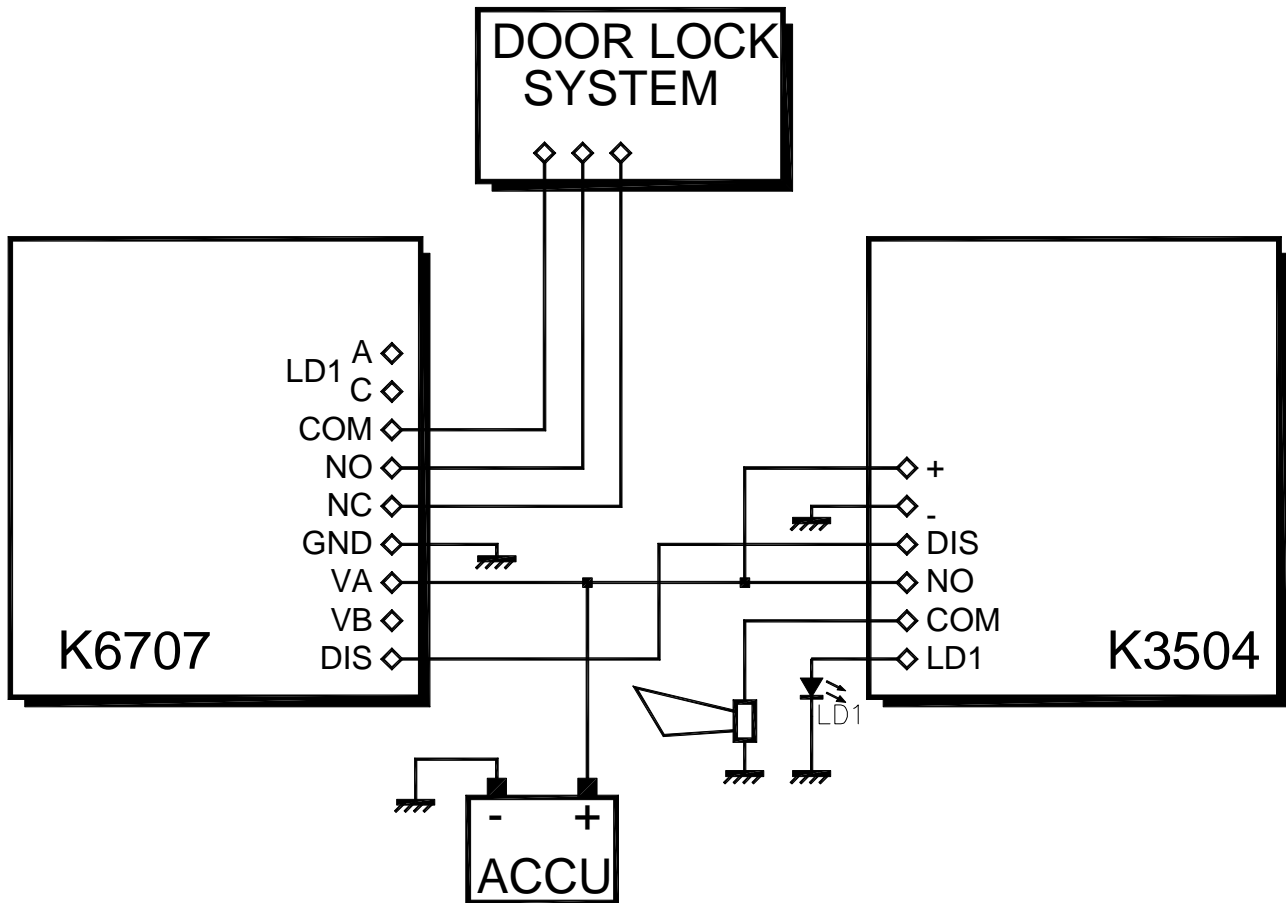

# Infrared code lock receiver working together with the car alarm (K3501)

K6709

