

Car burglar alarm used as stand alone unit, device connected to “+”

K3504

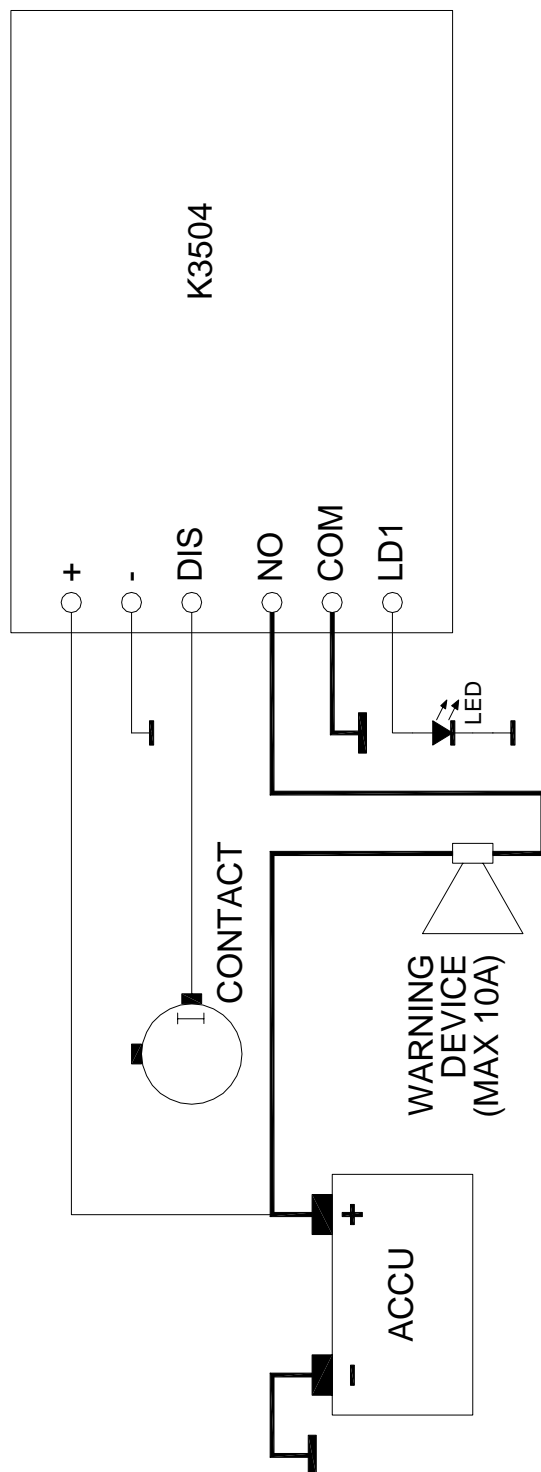

Car burglar alarm used as stand alone unit, device connected to chassis

K3504

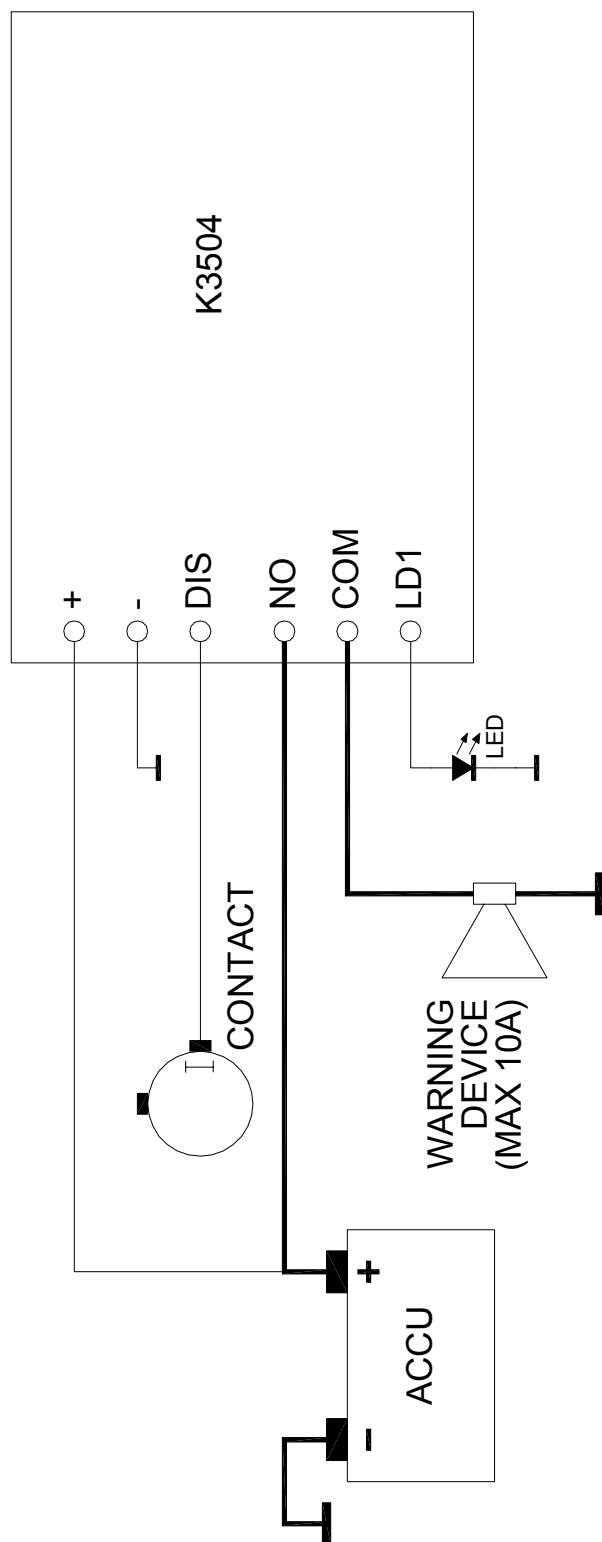

Car burglar alarm used in combination with IR-code lock K6704/K6705, device connected to "+"

K3504

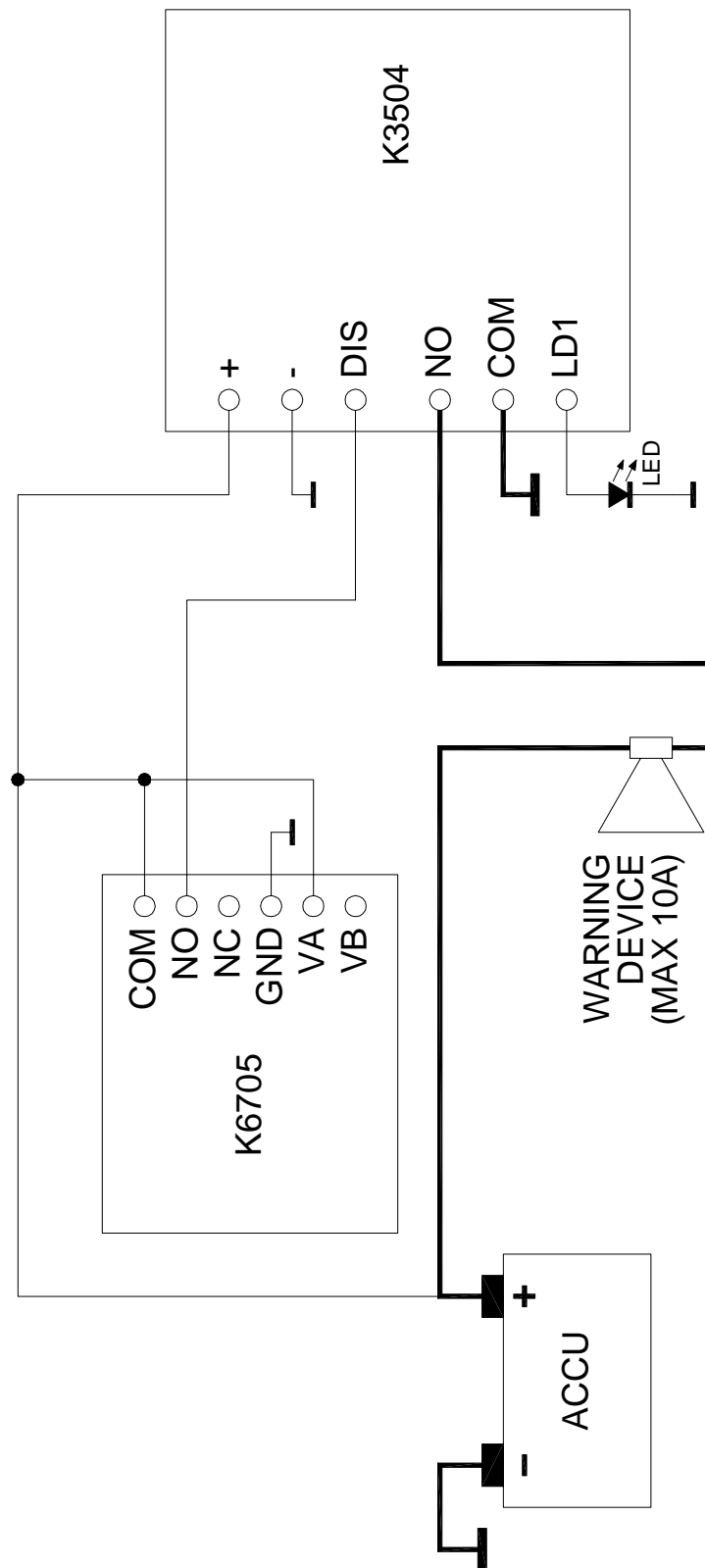

Car burglar alarm used in combination with IR-code lock K6704/K6705, device connected to "chassis"

K3504

