

MAXX TRONIC

THE QUALITY ELECTRONIC KIT SET & MODULE

ELECTRONIC DIMMER 4,000 W CODE MX056

The light dimmer is an electronic device used for dimming or adjusting light of electric bulbs and heat of stoves or electric pans. Its maximum capability is to be used with electrical appliances up to 4000 watts.

Technical specifications:

- voltage supply: 220-240VAC.
- maximum load: 4000 watts @ 220VAC
- dimming adj. by potentiometer
- PCB dimensions : 3.56 x 4.29 inches.

How to works:

The triac works as the switch of dimming-brightening operation, capable of the voltage control of the both cathode and anode poles. As illustrated in figure circuit it can be seen here that the current in each fragment will be divided into 180 degree fragment. If the triac can be controlled of its current induction at between 45-180 degree this means that the bulb will light about 50%. Following this principle, therefore, our task in this case is seeking to find an circuit capable of adjusting the tricking duration for the triac to induce the current from 0-180 degree, using R1 and VR1 to work in combination with C1 as a relay set, to trick the triac at particular grid. The diac will function to increase the voltage to the triac.

PCB assembly:

Shown in Figure 5 is the assembled PCB. Starting with the lowest height components first, taking care not to short any tracks or touch the edge connector with solder. Some tracks run under components, and care should be taken not to short out these tracks. If the pins will not enter the holes with ease, use a small drill to slightly enlarge the opening. All components with axial leads should be carefully bent to fit the position on the PCB and then soldered into place. Make sure that the electrolytic capacitors are inserted the correct way around. Some components are particularly sensitive to heat (ie: Transistors, IC's, diodes etc.) extra care must be taken to only apply the iron for as little time as possible, using a pair of pliers to grip the leads will help conduct heat away. Trim components leads with wire cutters to prevent excess lengths causing a short circuit. Now check that you really did mount them all the right way round!

Testing:

Connect the light bulb with 220V coil type more than 100 watts at "OUT 220VAC" point and connect the power cord at "IN 220VAC" point to wall outlet. Rotating the VR1 to min. counterclockwise, the bulb is light off. After rotating the VR1 to max. clockwise increases the lighting of the bulb.

Figure 1. Installing the components

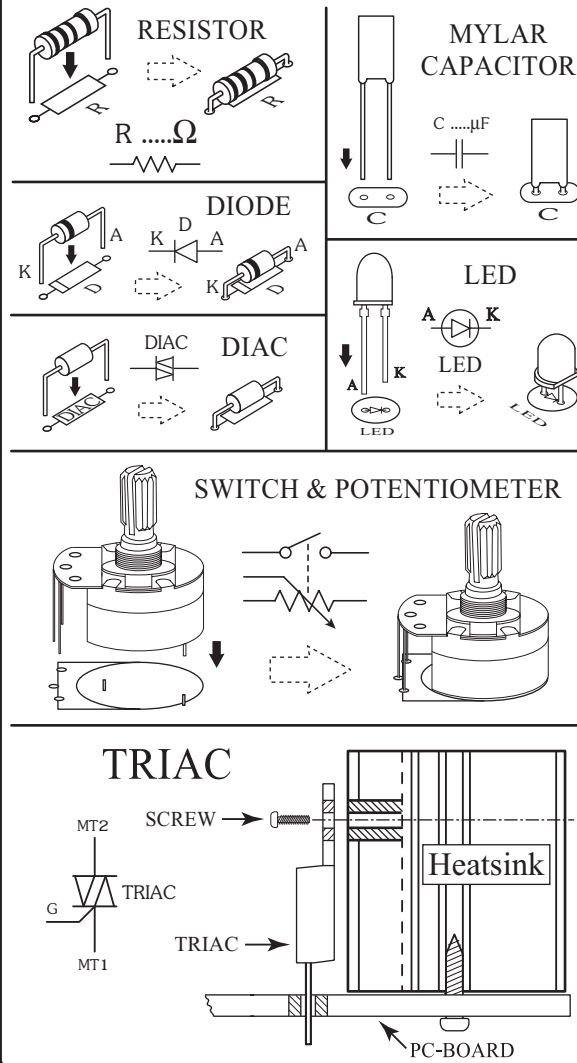

Troubleshooting:

The most problem like the fault soldering. Check all the soldering joint suspicious. If you discover the short track or the short soldering joint, re-solder at that point and check other the soldering joint. Check the position of all component on the PCB. See that there are no components missing or inserted in the wrong places. Make sure that all the polarised components have been soldered the right way round.

Figure 2. The electronic dimmer 4,000W circuit

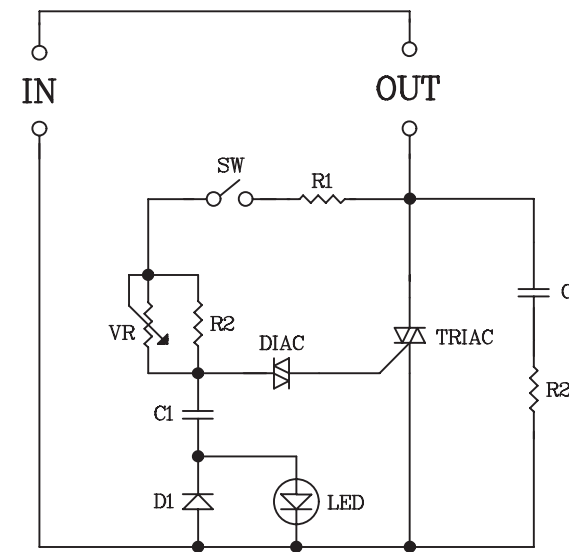

Figure 3.

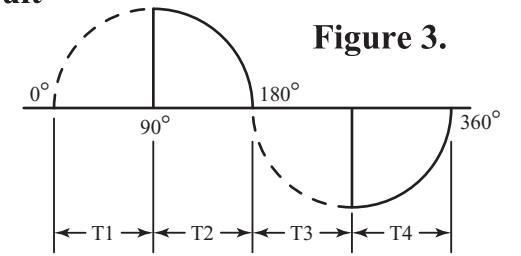

Figure 4.

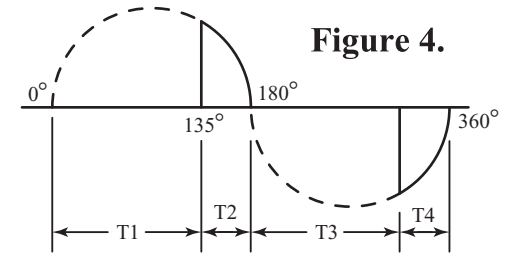

Figure 5. Connections

