

ANNOUNCED SPECIFICATION OF HS-325HB STANDARD BALL BEARING SERVO

1. TECHNICAL VALUE

CONTROL SYSTEM	: +PULSE WIDTH CONTROL 1500usec NEUTRAL	
OPERATING VOLTAGE RANGE	: 4.8V TO 6.0V	
TEST VOLTAGE	: AT 4.8V	AT 6.0V
OPERATING SPEED	: 0.19sec/60° AT NO LOAD	0.15sec/60° AT NO LOAD
STALL TORQUE	: 3kg.cm(41.66oz.in)	3.7kg.cm(51.38oz.in)
IDLE CURRENT	: 7.4mA AT STOPPED	7.7mA AT STOPPED
RUNNING CURRENT	: 160mA/60° AT NO LOAD	180mA/60° AT NO LOAD
STALL CURRENT	: 700mA	800mA
DEAD BAND WIDTH	: 5usec	5usec
OPERATING TRAVEL	: 40°/ONE SIDE PULSE TRAVELING 400usec	
DIRECTION	: CLOCK WISE/PULSE TRAVELING 1500 TO 1900usec	
MOTOR TYPE	: CORED METAL BRUSH	
POTENTIOMETER TYPE	: 4 SLIDER/DIRECT DRIVE	
AMPLIFIER TYPE	: ANALOG CONTROLLER & TRANSISTOR DRIVER	
DIMENSIONS	: 40x20x36.5mm(1.57x0.78x1.43in)	
WEIGHT	: 43g(1.51oz)	
BALL BEARING	: TOP/BALL BEARING	
GEAR MATERIAL	: 2 HEAVY DUTY RESIN	
HORN GEAR SPLINE	: 24 SEGMENTS/ø5.76	
SPLINED HORNS	: RESULAR/R-C,R-D,R-I,R-O,R-X,SUPER/R-XA	
CONNECTOR WIRE LENGTH	: 300mm(11.81in)	
CONNECTOR WIRE STRAND COUNTER	: 40EA	
CONNECTOR WIRE GAUGE	: 25AWG	

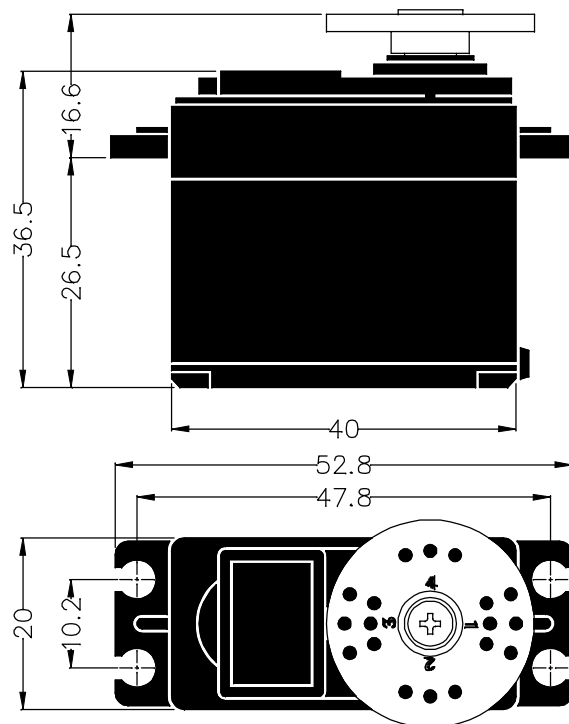

2. FEATURES

LONG LIFE POTENTIOMETER, TOP BALL BEARING, 2 HEAVY DUTY RESIN GEARS

3. APPLICATIONS

AIRCRAFT 20-40 SIZE, STEERING AND THROTTLE SERVO FOR CARS, TRUCK AND BOATS