

GENERAL SPECIFICATION OF HS-635HB HIGH TORQUE SERVO

1. TECHNICAL VALUE

CONTROL SYSTEM	: +PULSE WIDTH CONTROL 1500usec NEUTRAL	
OPERATING VOLTAGE RANGE	: 4.8V TO 6.0V	
OPERATING TEMPERATURE RANGE	: -20°C TO +60°C (-4°F TO +140°F)	
TEST VOLTAGE	: AT 4.8V	: AT 6.0V
OPERATING SPEED	: 0.18sec/60° AT NO LOAD	: 0.15sec/60° AT NO LOAD
STALL TORQUE	: 6.4kg.cm(88.87oz.in)	: 7.8kg.cm(108.31oz.in)
STANDING TORQUE	: 5.1kg.cm(70.82oz.in)/5° HOLD OUT	: 6.2kg.cm(86.10oz.in)/5° HOLD OUT
IDLE CURRENT	: 7.4mA AT STOPPED	: 7.7mA AT STOPPED
RUNNING CURRENT	: 400mA/60° AT NO LOAD	: 500mA/60° AT NO LOAD
STALL CURRENT	: 2000mA	: 2500mA
DEAD BAND WIDTH	: 5usec	: 5usec
OPERATING TRAVEL	: 40°/ONE SIDE PULSE TRAVELING 400usec	
DIRECTION	: CLOCK WISE/PULSE TRAVELING 1500 TO 1900usec	
MOTOR TYPE	: CORED METAL BRUSH	
POTENTIOMETER TYPE	: 6 SLIDER/INDIRECT DRIVE	
AMPLIFIER TYPE	: ANALOG AMPLIFIER WITH TRANSISTOR DRIVER	
DIMENSIONS	: 39.8x19.8x38.8mm(1.56x0.77x1.52in)	
WEIGHT	: 52.1g(1.83oz)	
BALL BEARING	: DUAL/MR106	
GEAR MATERIAL	: HEAVY DUTY RESIN	
HORN GEAR SPLINE	: 24 SEGMENTS/∅5.76	
SPLINED HORNS	: HEAVY DUTY/HD-IS, HD-O, HD-LS, SUPER/R-XA	
CONNECTOR WIRE LENGTH	: 300mm(11.81in)	
CONNECTOR WIRE STRAND COUNTER	: 60EA	
CONNECTOR WIRE GAUGE	: 22AWG	

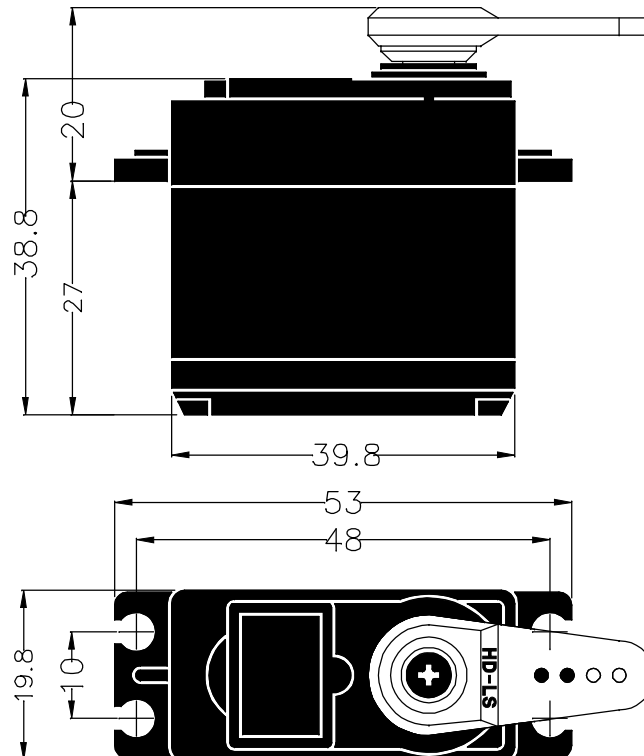

2. FEATURES

DURABLE HEAVY DUTY RESIN GEARS WITH BALL BEARINGS

3. APPLICATIONS

OFFROAD 1/8, 1/10 MONSTER TRUCK(TRAXXAS T-MAX, E-MAX ETC)

55-78inch or 1.4 meter-2 meter WINGSPAN'S SPORT AIRPLANE(ARF SPORT AEROBATIC, SCALE PLANES)

30 CLASS HELICOPTERS