

Features

- Efficiency up to 97%, Non isolated, no need for heatsinks
- Pin-out compatible with LM78XX Linears
- Very low profile(L*W*H=11.5*7.5*10.2)
- Wide input range.(4.75V ~ 32V)
- Short circuit protection, Thermal shutdown
- Non standard outputs available as specials
- Low ripple and noise
- UL94V-0 package material
- EMC, Safety Certified
- See Innoline Application Notes for use as an inverter (alternative to LM79xx Linear)

Description

The R-78xx-Series high efficiency switching regulators are ideally suited to replace 78xx linear regulators and are pin compatible. The efficiency of up to 97% means that very little energy is wasted as heat so there is no need for any heat sinks with their additional space and mounting costs. Low ripple and noise figures and short circuit , overload and over-temperature protection round off the specifications of this versatile converter series. This R-78xx-0.5 is fully certified to EN 60601-1-2 (Medical Equipment), EN 55022 (Emissions), and EN55024 (Immunity) EMC Standards and for EN-60950-1 Safety.

Selection Guide

Part Number SIP3	Input Range (V)	Output Voltage (V)	Output Current (A)	Efficiency	
				Min. Vin (%)	Max. Vin (%)
R-781.5-0.5	4.75 – 30 ⁽¹⁾	1.5	0.5	73	63
R-781.8-0.5	4.75 – 32	1.8	0.5	82	71
R-782.5-0.5	4.75 – 32	2.5	0.5	87	77
R-783.3-0.5	4.75 ⁽²⁾ – 32	3.3	0.5	91	81
R-785.0-0.5	6.5 – 32	5.0	0.5	94	86
R-786.5-0.5	8.0 – 32	6.5	0.5	95	88
R-789.0-0.5	11 – 32	9.0	0.5	96	92
R-7812-0.5	15 – 32	12	0.5	97	94
R-7815-0.5	18 – 32	15	0.5	97	95

Note 1: 1.5V Output can be unstable with Vin>30VDC
 Note 2: Refer to Dynamic Load Stability

Standard Application Circuit

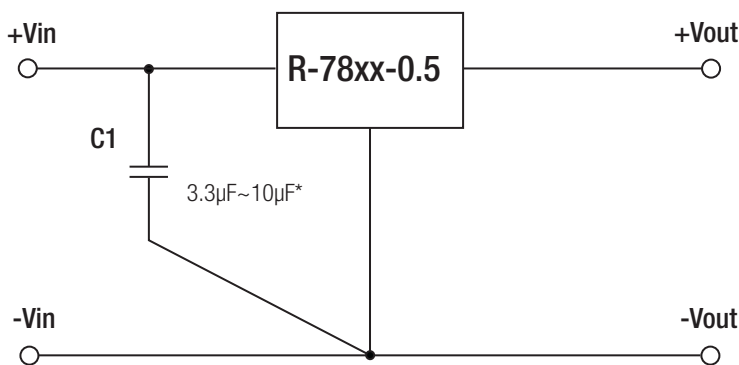

* Input capacitor required if Vin>26VDC (3.3µF) or if the supply is a battery or other low impedance source (4.7µF~10µF)
 Capacitor should be electrolytic or MLCC with 1R resistor in series

INNOLINE
 DC/DC-Converter
 with 3 year Warranty



0.5 AMP
SIP3
Single Output



EN-55022 Certified
EN-55024 Certified
EN-60601-1-2 Certified
EN-60950-1 Certified

R-78-0.5

Derating-Graph (Ambient Temperature)

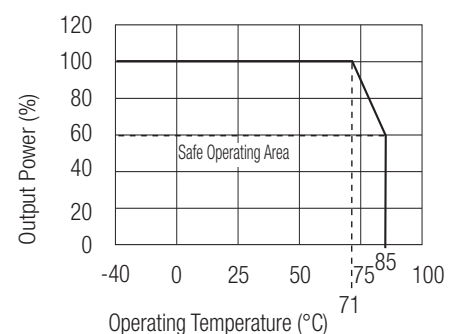

Specifications (typical at 25°C, 10% minimum load, unless otherwise specified)

Characteristics	Conditions	Min.	Typ.	Max.
Input Voltage Range	1.5V	4.75	30V	34V abs. max.
	1.8V to 15.5V	4.75	32V	34V abs. max.
Output Voltage Range (for customized parts)	All Series	1.25		15.5V
Output Current (see note)	All Series	0*		500mA
Output Current Limit	All Series			2000mA
Short Circuit Input Current (Vin = 24V)	All Series			60mA
Internal Power Dissipation				0.4W
Short Circuit Protection			Continuous, automatic recovery	
Output Voltage Accuracy (At 100% Load)	All Series		±2	±3%
Line Voltage Regulation (Vin = min. to max. at full load)	1.5V to 6.5V		0.2	0.4%
	9V to 15.5V		0.1	0.2%
Load Regulation (10 to 100% full load)	1.5V to 6.5V		0.4	0.6%
	9V to 15.5V		0.25	0.4%
Note: Operation under no load will not damage these devices, however they may not meet all specifications. A minimum load of 6mA is recommended				
Dynamic Load Stability	100% <-> 50% load		±75mV	
	100% <-> 10% load			±100mV
Note: The R-783.3-0.5 requires Vin>5.5V to meet the Dynamic Load Stability Specification.				
Ripple & Noise (without Output Capacitor)	1.5V to 6.5V		20mVp-p	30mVp-p
	9V to 15.5V		30mVp-p	40mVp-p
Ripple & Noise (with Output Capacitor=100µF)	1.5V to 6.5V		15mVp-p	20mVp-p
	9V to 15.5V		25mVp-p	35mVp-p
Temperature Coefficient	-40°C ~ +85°C ambient			0.015%/°C
Max capacitance Load	with normal start-up time, no external components			220µF
	with <1 second start up time + diode protection circuit			6800µF
Switching Frequency		280	330	380kHz
Quiescent Current	Vin = min. to max. at 0% load		5	7mA
Operating Temperature Range		-40°C		+85°C
Operating Case Temperature				+100°C
Storage Temperature Range		-55°C		+125°C
Case Thermal Impedance				70°C / W
Thermal Shutdown	Internal IC junction			+160°C
Conducted Emissions	EN55022			Class B
Radiated Emissions	EN55022			Class B
ESD	EN61000-4-2			Class A
Radiated Immunity	EN61000-4-3			Class A
Fast Transient	EN61000-4-4			Class A
Conducted Immunity	EN61000-4-6			Class A
Magnetic Field Immunity	EN61000-4-8			Class A
Medical Grade EMC	EN60601-1-2			
Package Weight			1.9g	
Packing Quantity				42pcs per Tube
MTBF (+25°C) (+71°C)	} Detailed Information see Application Notes chapter "MTBF"	using MIL-HDBK 217F		21098 x 10 ³ hours
		using MIL-HDBK 217F		4212 x 10 ³ hours
Certifications				
EN General Safety	Report: PS080803950		EN 60950-1:2001 + All:2004	
EN Medical EMC	Report: 5A111502E		EN 60950-1-1-2:2002	
EMC	Report: 5A111502E		EN55022, EN61000, EN55024	

Characteristics

Efficiency

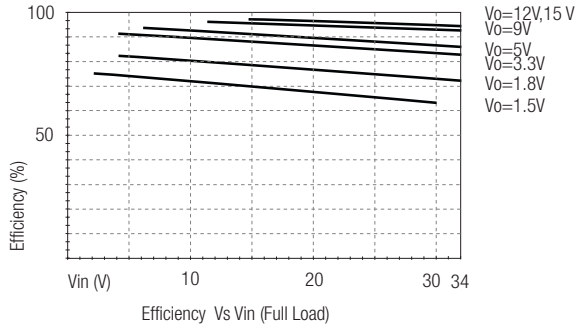

Ripple

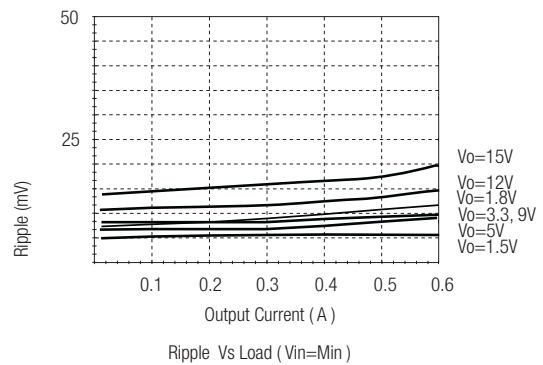
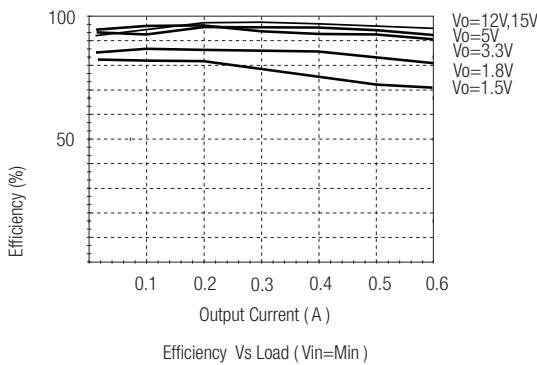
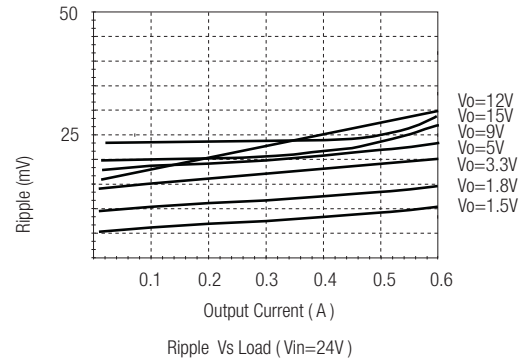
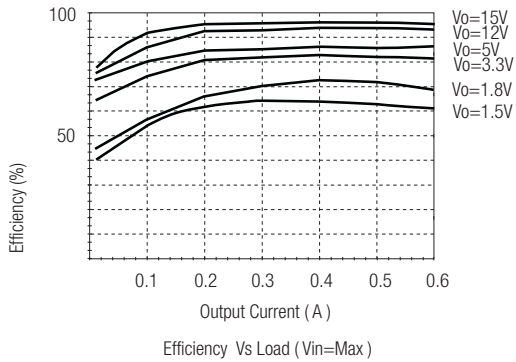
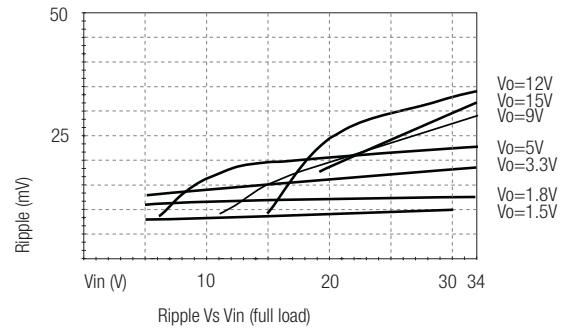

Optional Diode Protection Circuit

Optional Protection 1:

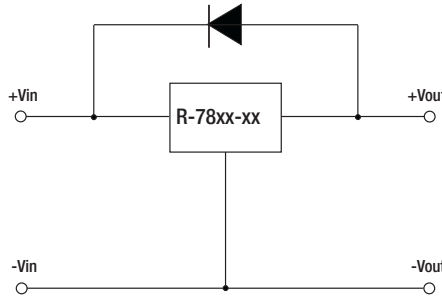

Add a blocking diode to Vout if current can flow backwards into the output, as this can damage the converter when it is powered down.

The diode can either be fitted across the device if the source is low impedance or fitted in series with the output (recommended).

Optional Protection 2:

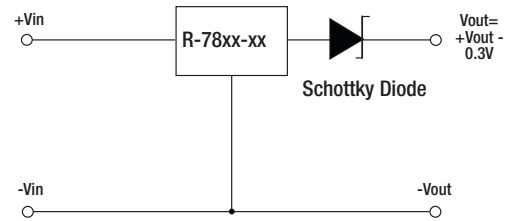

Application example:
Driving a high capacitive load

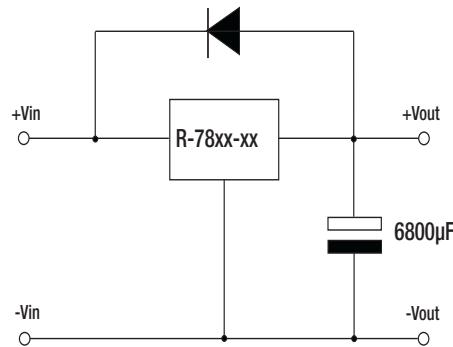

Application Examples

High efficiency, isolated, dual unregulated outputs

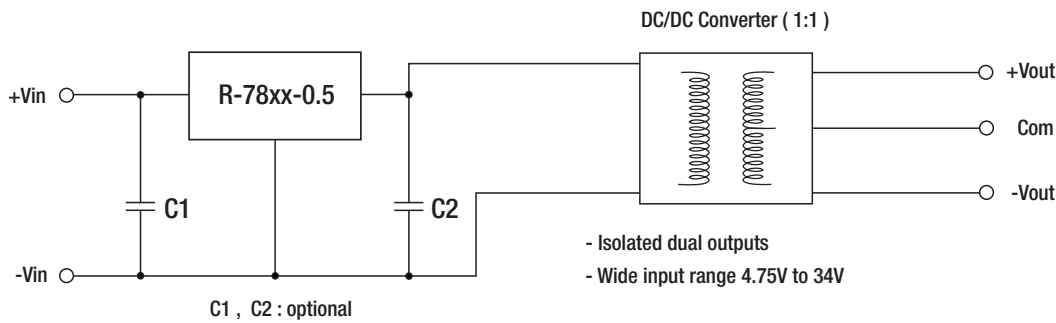

R-78-0.5

Isolated (up to 6KV), wide Input range regulated output

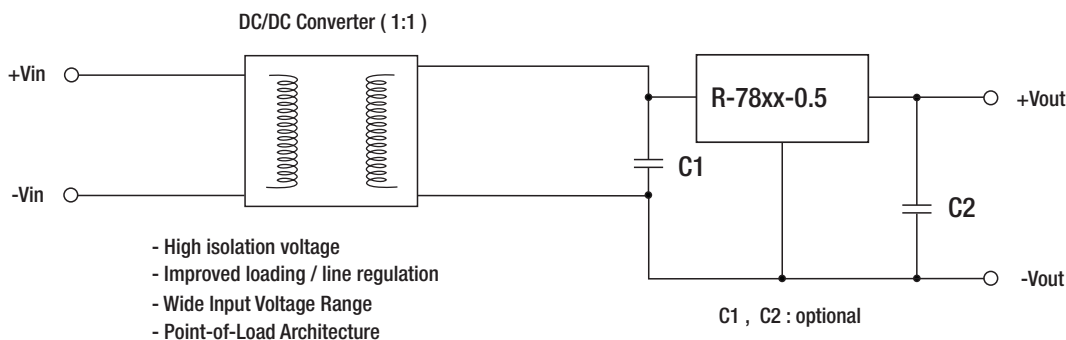

Package Style and Pinning (mm)

SIP3 PIN Package

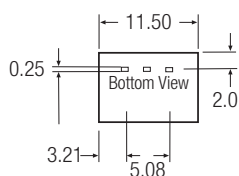
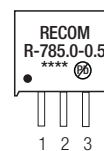
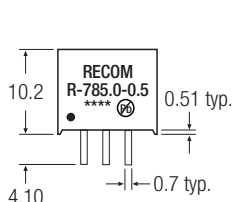

Recommended Footprint Details

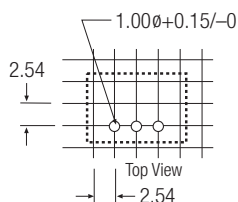

Pin Connections

Pin #	Connection
1	+Vin
2	GND
3	+Vout

xx.x ±0.5mm
xx.xx ±0.25mm