

Document No. _____

Customer: _____

SHENHUI TECHNOLOGY

Model: SVM802BS (COB)

Address: Block513, 4th floor,
Beguiling Industrial Area
Shenzhen, China

Tel: 0755-25843715

Fax: 0755-82262915

DSG'D _____

APP'D _____

Revision	Document No.	
	Document Rev.	0

Data	Sheet No.	Summary
		NEW

CONTENTS	Document No.	
	Document Rev.	0

Section/Sub Section	Pages	Rev.
1、 Basic Specifications	1	0
1.1、 Display Specifications		0
1.2、 Block Diagram		0
1.3、 Pin Connection		0
2、 Absolute Maximum Ratings	1	0
3、 Electrical Characteristics	5	0
3.1、 DC Characteristics		0
3.2、 Timing Chart		0
3.3、 AC Characteristics		0
3.4、 Explanation of Command		0
4、 Operating Characteristics	4	0
4.1、 Initializing By Instruction		0
4.2、 Display Data RAM (DDRAM)		0
4.3、 Relationship Between DDRAM And CGROM		0
4.4、 CGROM Character Code Table		0
5、 Optical Characteristics	3	0
5.1、 Optical Characteristics		0
5.2、 Definition of Optical Characteristics		0
6、 Reliability Test	1	0
6.1、 Content of Reliability Test		0
6.2、 Failure Judgment Criterion		0
7、 Precautions for Use of LCD Module	2	0
7.1、 Handling Precautions		0
7.2、 Storage Precautions		0
7.3、 Design Precautions		0
7.4、 Other		0

CONTENTS	Document No.	
	Document Rev.	0

Section/Sub Section	Pages	Rev.
8、 Visual Inspection	1	0
8.1、 Air Bubbles		0
8.2、 Black/White Spots		0
8.3、 Black/White Lines		0

Document	Specifications	No.	
Section	1. Basic Specifications	Sheet	1/1
		Rev.	0

1.1、 Display Specifications

- A) Display Mode STN/TN, Positive, Reflective/Transflective
 B) Viewing Angle 6 O'clock Direction
 C) Display 8 Character X 2 line

1.2、 Block Diagram

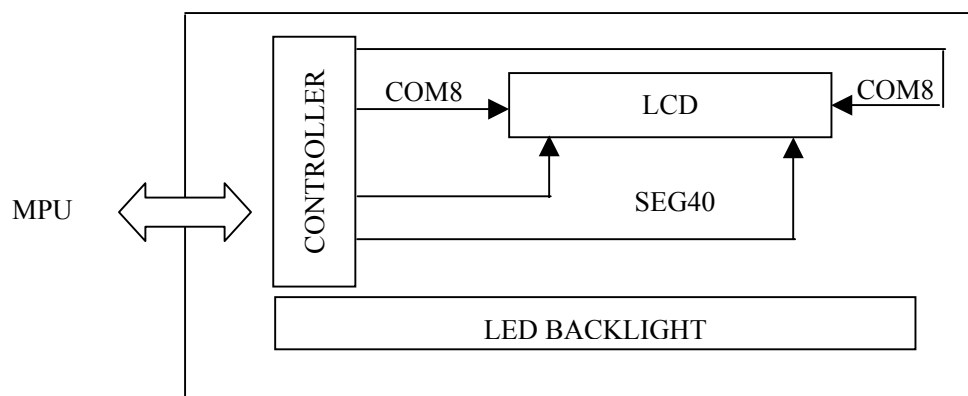

1.3、 Pin Connection

NO.	SYMBOL	FUNCTION
1	Vss	Power Supply 0V
2	Vdd	Power Supply +5V
3	Vlcd	Operating voltage for LCD Drive.
4	RS	Data/Command selection input. RS= "H" Data Input. RS= "L" Instruction Input
5	R/W	Read/write selection input. RW = "H" Read Operation. RW = "L" Write Operation.
6	E	Read/ Write enable signal. Active high. When this signal is kept low, the data bus is fetched.
7~14	DB0~DB7	Data bus 0~7
15	NC	No connect
16	NC	No connect

Document	Specifications	No.	
Section	2.Absolute Maximum Ratings	Sheet	1/1
		Rev.	0

2、 Absolute Maximum Ratings

Items	Symbol	Test Condition	Standard Value.		Unit
			Min	Max	
Power Supply Voltage	VDD	—	0	+7	V
	VLCD	—	0	+5.5	V
Input Voltage	V1	—	Vss	Vdd	V
Operating Temperature	Top	—	0	+50	°C
Storage Temperature	Tstg	—	-20	+60	°C

Document	Specifications	No.	
Section	3. Electrical Characteristics	Sheet	1/5
		Rev.	0

3.1、DC Characteristics

Items	Symbol	Min.	Typ.	Max.	Unit	Terminal
Power Supply Voltage	VDD	4.5	5.0	5.5	V	VDD
	V0-VSS	3.0	-	5.5	V	V0
“0”Input Voltage	VIL	-0.3	-	0.6	V	*1
“1”Input Voltage	VIH	2.2	-	VDD	V	
Input Leak Current	IIL	-150	-300	-500	uA	
Power Supply Current(*3)	IDD	-	0.5	2.0	mA	VDD

*1: Rs/[R/w]/E/DB[7:0]

*2 Measuring Condition : VDD=5.0V±5% T=25°C

3.2、Timing Chart

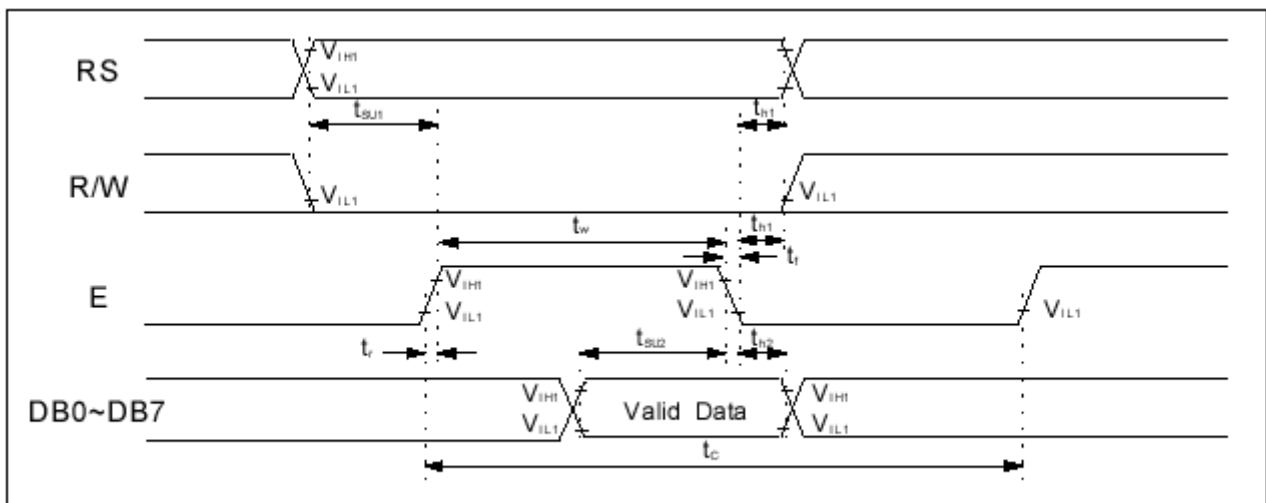

Write Mode Timing Diagram

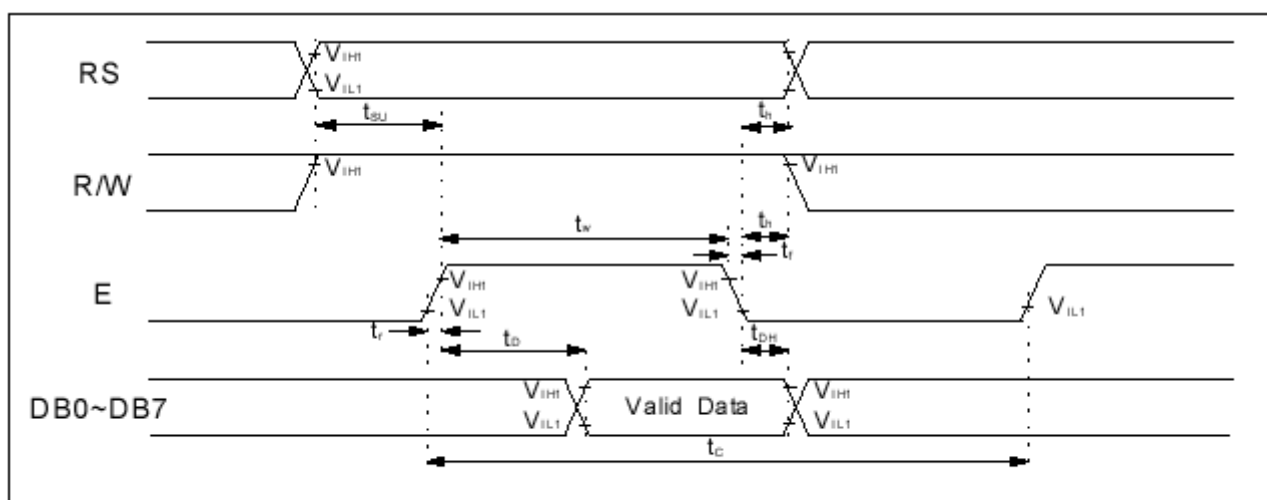

Read Mode Timing Diagram

Document	Specifications	No.	
Section	3. Electrical Characteristics	Sheet	2/5
		Rev.	0

3.3、AC Characteristics

Mode	Characteristic	Symbol	Min.	Typ.	Max.	Unit
Write Mode	E Cycle Time	tc	500	-	-	ns
	E Rise / Fall Time	t _R ,t _F	-	-	20	
	E Pulse Width (High, Low)	tw	230	-	-	
	R/W and RS Setup Time	tsu1	40	-	-	
	R/W and RS Hold Time	t _{H1}	10	-	-	
	Data Setup Time	tsu2	80	-	-	
	Data Hold Time	t _{H2}	10	-	-	
Read Mode	E Cycle Time	tc	500	-	-	ns
	E Rise / Fall Time	t _R ,t _F	-	-	20	
	E Pulse Width (High, Low)	tw	230	-	-	
	R/W and RS Setup Time	tsu	40	-	-	
	R/W and RS Hold Time	t _H	10	-	-	
	Data Output Delay Time	t _D	-	-	120	
	Data Hold Time	t _{DH}	5	-	-	

3.4、Explanation of Command

3.4.1、Clear Display

CODE:

RS	R/W	DB7	DB6	DB5	DB4	DB3	DB2	DB1	DB0
L	L	L	L	L	L	L	L	L	H

Clear all the display data by writing "20H" (space code) to all DDRAM address, and set DDRAM address to "00H" in the AC (address counter). Return cursor to the original status, namely, bring the cursor to the left edge on first line of the display. Make entry mode increment (I/D = "1").

3.4.2、Return Home

CODE:

RS	R/W	DB7	DB6	DB5	DB4	DB3	DB2	DB1	DB0
L	L	L	L	L	L	L	L	H	X

Return Home is cursor return home instruction. Set DDRAM address to "00H" in the address counter. Return cursor to its original site and return display to its original status, if shifted. Contents of DDRAM does not change.

Document	Specifications	No.	
Section	3. Electrical Characteristics	Sheet	3/5
		Rev.	0

3.4.3、 Entry Mode Set

CODE:

RS	R/W	DB7	DB6	DB5	DB4	DB3	DB2	DB1	DB0
L	L	L	L	L	L	L	H	I/D	SH

Set the moving direction of cursor and display.

When I/D = "1", cursor/blink moves to right and DDRAM address is increased by 1.

When I/D = "0", cursor/blink moves to left and DDRAM address is decreased by 1.

SH: Shift of Entire Display

When DDRAM read (CGRAM read/write) operation or SH = L, shift of entire display is not performed. If SH =H and DDRAM write operation, shift of entire display is performed according to I/D value (I/D = H : shift left, I/D= L: shift right).

3.4.4、 Display ON / OFF Control

CODE:

RS	R/W	DB7	DB6	DB5	DB4	DB3	DB2	DB1	DB0
L	L	L	L	L	L	H	D	C	B

Control display/cursor/blink ON/OFF 1 bit register.

D : Display ON/OFF Control Bit

When D = "1", entire display is turned on.

When D = "0", display is turned off, but display data remained in DDRAM.

C : Cursor ON/OFF Control Bit

When C = "1", cursor is turned on.

When C = "0", cursor is disappeared in current display, but I/D register remains its data.

B : Cursor Blink ON/OFF Control Bit

When B = "1", cursor blink is on, which performs alternate between all the "1" data and display character at the cursor position.

When B = "0", blink is off.

3.4.5、 Set CGRAM Address

CODE:

RS	R/W	DB7	DB6	DB5	DB4	DB3	DB2	DB1	DB0
L	L	L	H	ACG5	ACG4	ACG3	ACG2	ACG1	ACG0

Set CGRAM address to AC. This instruction makes CGRAM data available from MPU.

Document	Specifications	No.	
Section	3. Electrical Characteristics	Sheet	4/5
		Rev.	0

3.4.6. Cursor or Display Shift

CODE:

RS	R/W	DB7	DB6	DB5	DB4	DB3	DB2	DB1	DB0
L	L	L	L	L	H	S/C	R/L	X	X

Shift Patterns According to S/C and R/L Bits

S/C	R/L	Operation
0	0	Shift cursor to the left, AC is decreased by 1
0	1	Shift cursor to the right, AC is increased by 1
1	0	Shift all the display to the left, cursor moves according to the display
1	1	Shift all the display to the right, cursor moves according to the display

3.4.7. Function Set

CODE:

RS	R/W	DB7	DB6	DB5	DB4	DB3	DB2	DB1	DB0
L	L	L	L	H	DL	N	F	X	X

DL : Interface data length control bit

When DL = "1", it means 8-bit bus mode with MPU.

When DL = "0", it means 4-bit bus mode with MPU. So to speak, DL is a signal to select 8-bit or 4-bit bus mode.

When 4-bit bus mode, it needs to transfer 4-bit data in two times.

N : Display line number control bit

When N = "0", it means 1-line display mode.

When N = "1", 2-line display mode is set.

F : Display font type control bit

When F = "0", 5 × 7 dots format display mode

When F = "1", 5 × 10 dots format display mode.

3.4.8. Set DDRAM Address

CODE:

RS	R/W	DB7	DB6	DB5	DB4	DB3	DB2	DB1	DB0
L	L	H	ADD6	ADD5	ADD4	ADD3	ADD2	ADD1	ADD0

Set DDRAM address to AC. This instruction makes DDRAM data available from MPU.

Document	Specifications	No.	
Section	3. Electrical Characteristics	Sheet	5/5
		Rev.	0

When 1-line display mode(N = 0), DDRAM address is from "00H" to "4FH". In 2-line display mode (N = 1), DDRAM address in the 1st line is from "00H" to "27H", and DDRAM address in the 2nd line is from "40H" to "67H".

3.4.9、 Read Busy Flag & Address

CODE:

RS	R/W	DB7	DB6	DB5	DB4	DB3	DB2	DB1	DB0
L	H	BF	AC6	AC5	AC4	AC3	AC2	AC1	AC0

This instruction shows whether module is in internal operation or not.

If the resultant BF is "1", it means the internal operation is in progress and you have to wait until BF to be Low, and then the next instruction can be performed. In this instruction you can read also the value of address counter.

3.4.10、 Write Data to RAM

CODE:

RS	R/W	DB7	DB6	DB5	DB4	DB3	DB2	DB1	DB0
H	L	D7	D6	D5	D4	D3	D2	D1	D0

Write binary 8-bit data to DDRAM/CGRAM.

The selection of RAM from DDRAM, and CGRAM, is set by the previous address set instruction: DDRAM address set, CGRAM address set). RAM set instruction can also determine the AC direction to RAM. After write operation, the address is automatically increased/decreased by 1, according to the entry mode.

3.4.11、 Read Data from RAM

CODE:

RS	R/W	DB7	DB6	DB5	DB4	DB3	DB2	DB1	DB0
H	H	D7	D6	D5	D4	D3	D2	D1	D0

Read binary 8-bit data from DDRAM/CGRAM.

The selection of RAM is set by the previous address set instruction. If the address set instruction of RAM is not performed before this instruction, the data that is read first is invalid, because the direction of AC is not determined. If you read RAM data several times without RAM address set instruction before read operation, you can get correct RAM data from the second, but the first data would be incorrect, because there is no time margin to transfer RAM data. In case of DDRAM read operation, cursor shift instruction plays the same role as DDRAM address set instruction; it also transfer RAM data to output data register. After read operation address counter is automatically increased/decreased by 1 according to the entry mode. After CGRAM read operation, display shift may not be executed correctly.

Document	Specifications	No.	
Section	4.Opertating Characteristics	Sheet	1/4
		Rev.	0

4.1、Initializing By Instruction

4.1.1、8-bit Interface Mode:

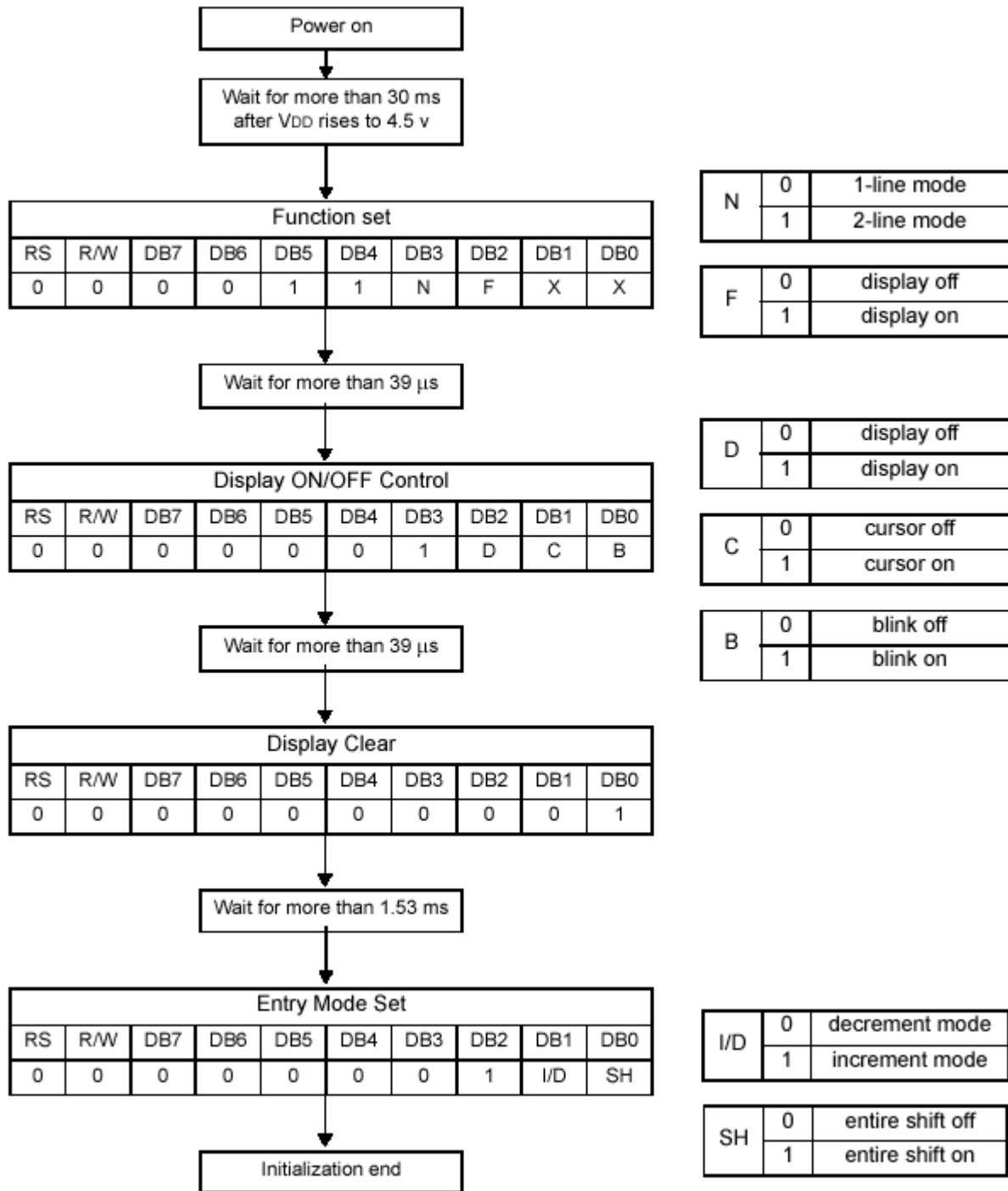

Document	Specifications	No.	
Section	4.Opertating Characteristics	Sheet	2/4
		Rev.	0

4.1.2、 4-bit Interface Mode:

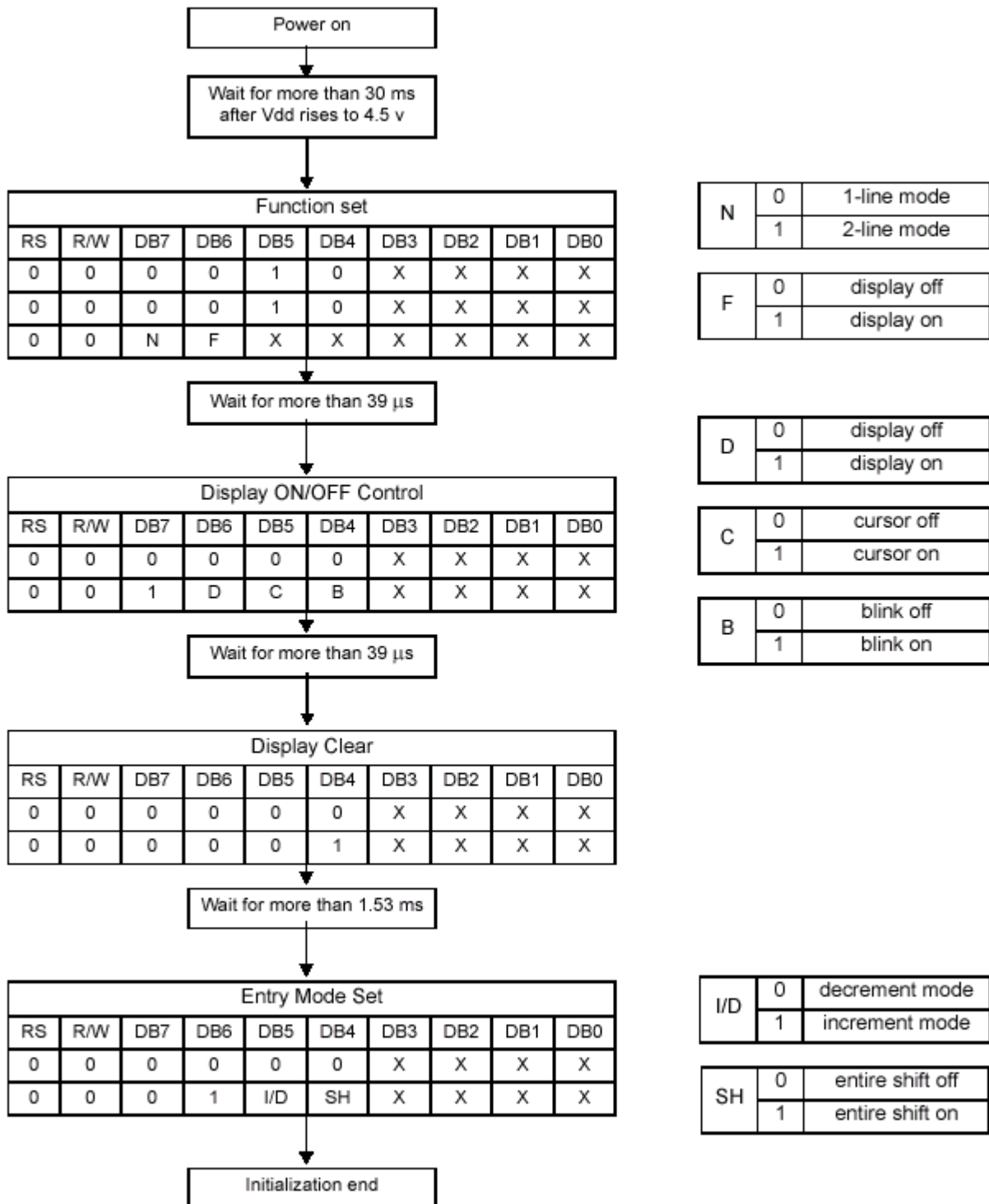

Document	Specifications	No.	
Section	4.Operating Characteristics	Sheet	3/4
		Rev.	0

4.2、Display Data Ram(DDRAM)

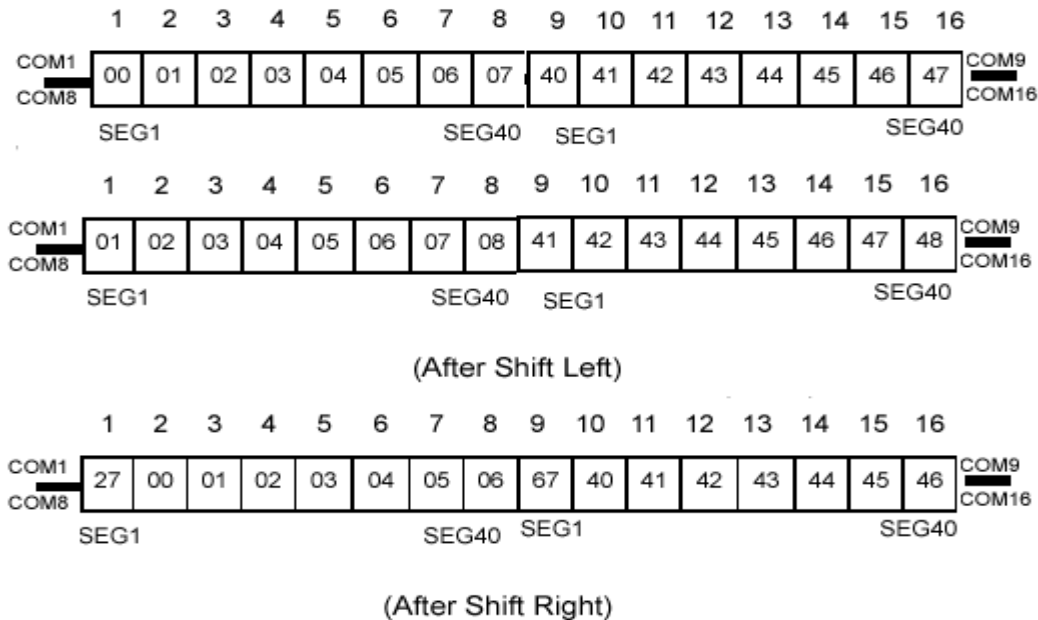

4.3、Relationship Between DDRAM and CGROM

Character Code (DDRAM data)								CGRAM Address						CGRAM Data								Pattern number
D7	D6	D5	D4	D3	D2	D1	D0	A5	A4	A3	A2	A1	A0	P7	P6	P5	P4	P3	P2	P1	P0	
0	0	0	0	x	0	0	0	0	0	0	0	0	0	x	x	x	0	1	1	1	0	pattern 1
											0	0	1				1	0	0	0	1	
											0	1	0				1	0	0	0	1	
											0	1	1				1	1	1	1	1	
											1	0	0				1	0	0	0	1	
											1	0	1				1	0	0	0	1	
											1	1	0				1	0	0	0	1	
											1	1	1				0	0	0	0	0	
0	0	0	0	x	1	1	1	0	0	0	0	0	0	x	x	x	1	0	0	0	1	pattern 8
											0	0	1				1	0	0	0	1	
											0	1	0				1	0	0	0	1	
											0	1	1				1	1	1	1	1	
											1	0	0				1	0	0	0	1	
											1	0	1				1	0	0	0	1	
											1	1	0				1	0	0	0	1	
											1	1	1				0	0	0	0	0	

Document	Specifications	No.	
Section	4.Opertating Characteristics	Sheet	4/4
		Rev.	0

4.4、CGROM Character Code Table

Character Generator ROM: 8320bits (192 cha. X 5 x 7 dots) Character Generator RAM: 64 x 8 bits (8 cha. X 5 x 7 dots)

Upper 4 Bits Lower 4 Bits	0000	0001	0010	0011	0100	0101	0110	0111	1000	1001	1010	1011	1100	1101	1110	1111
xxxx0000	CG RAM (1)			0	1	A	Q	a	q			-	タ	ミ	α	ρ
xxxx0001	(2)		!	1	A	Q	a	q			。	ア	チ	△	ä	q
xxxx0010	(3)		"	2	B	R	b	r			「	イ	ツ	×	β	θ
xxxx0011	(4)		#	3	C	S	c	s			」	ウ	テ	ε	ε	ω
xxxx0100	(5)		\$	4	D	T	d	t			、	エ	ト	φ	μ	Ω
xxxx0101	(6)		%	5	E	U	e	u			・	オ	ナ	1	ε	Ü
xxxx0110	(7)		&	6	F	V	f	v			ヲ	カ	ニ	ヨ	ρ	Σ
xxxx0111	(8)		'	7	G	W	g	w			ヲ	キ	ヌ	ラ	g	π
xxxx1000	(1)		<	8	H	X	h	x			イ	ク	ネ	リ	♪	×
xxxx1001	(2))	9	I	Y	i	y			ウ	ケ	ル		ˆ	γ
xxxx1010	(3)		*	:	J	Z	j	z			エ	コ	ハ	レ	j	≠
xxxx1011	(4)		+	;	K	C	k	c			オ	サ	ヒ	ロ	*	π
xxxx1100	(5)		,	<	L	¥	l	l			カ	シ	フ	ワ	φ	円
xxxx1101	(6)		-	=	M]	m)			ユ	ス	ハ	ン	も	÷
xxxx1110	(7)		.	>	N	^	n	→			ヨ	セ	ホ	〃	ん	
xxxx1111	(8)		/	?	0	_	o	←			ツ	ソ	マ	°	ö	■

Document	Specifications	No.	
Section	5.Optical Characteristics	Sheet	1/3
		Rev.	0

5.1、 Optical Characteristics

(Reflective Mode)

Item	Symbol	Temp	Min.	Typ	Max.	Unit	Condition	
Vop	VDD-VSS	25	4.5	5	5.5	V		
Response Time	Tr	25		200		ms		
	Tf	25		80		ms		
Contrast Ratio	K	25		6.7			Reflective mode	
Viewing Angle	ϕ	25		38		deg.	$\theta = 0^\circ$	CR 2.0
				34		deg.	$\theta = 90^\circ$	
				38		deg.	$\theta = 180^\circ$	
				38		deg.	$\theta = 270^\circ$	

- Panel only characteristics
- 1/16 duty, 1/5 bias

5.2、 Definition of Optical Characteristics

5.2.1、 Optical Measuring Equipment

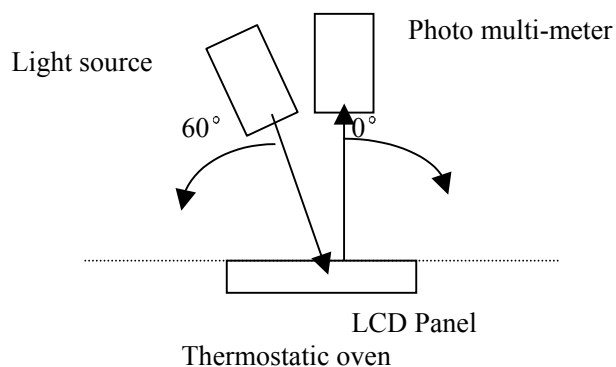

Specification Measuring Condition

Luxmeter: LCD-5100(OTSUKA ELECTRONICS)

Brightness Measuring Spot Diameter $\phi = 4.0\text{mm}$.

Document	Specifications	No.	
Section	5.Optical Characteristics	Sheet	2/3
		Rev.	0

5.2.2、Definition of Viewing Angle

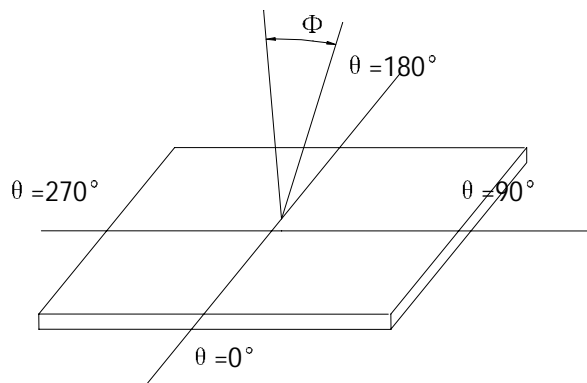

5.2.3、Definition of Response Time

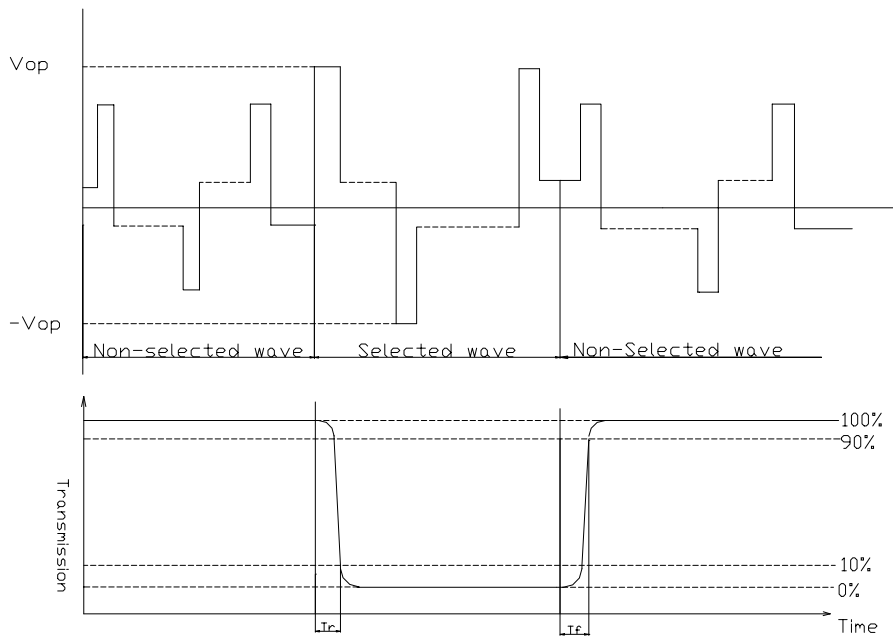

[Measuring Condition]

$$V_{op} = \frac{Vs50 + Vns50}{2}$$

$$\theta = \Phi = 0^\circ$$

Document	Specifications	No.	
Section	5.Optical Characteristics	Sheet	3/3
		Rev.	0

5.2.4、 Definition of Contrast Ratio

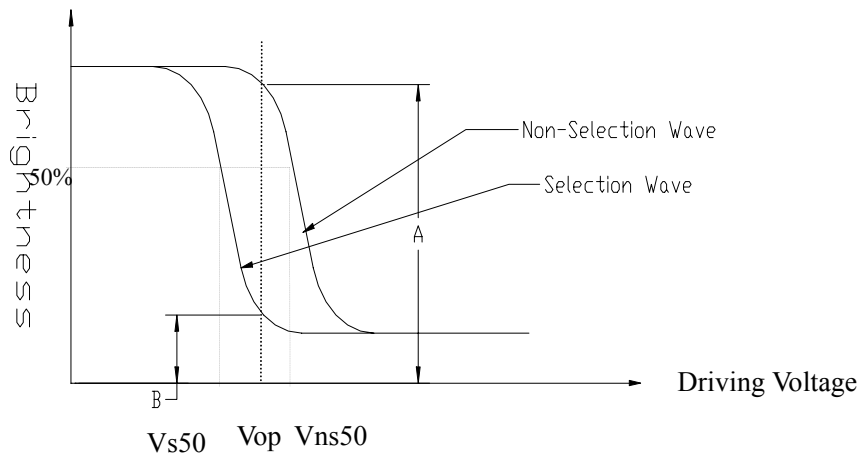

$$\text{Contrast Ratio} = \frac{\text{Brightness of Non-Selected condition (A)}}{\text{Brightness of Selected condition (B)}}$$

[Measuring Condition]

$$V_{op} = \frac{V_{s50} + V_{ns50}}{2}$$

$$\theta = \Phi = 0^\circ$$

Document	Specifications	No.	
Section	6.Reliability Test	Sheet	1/1
		Rev.	0

6.1、 Content of Reliability Test

No.	Test Item	Content of Test	Condition
Environmental Test			
1	High Temperature Storage	Endurance test applying the high temperature for a long time	80℃ 120H
2	Low Temperature Storage	Endurance test applying the low temperature for a long time	-30℃ 120H
3	High Temperature/Humidity Storage	Endurance test applying the high temperature and high humidity for a long time	80℃&90% RH 100H
4	Heat Shock	<p style="text-align: center;">Endurance test applying The low and high temperature cycles</p> <p style="text-align: center;"> $-30^{\circ}\text{C} \begin{array}{c} \leq \\ \geq \end{array} 80^{\circ}\text{C}$ ← (1H) ————— (1H) → 1 Cycle </p>	-30 / 80℃ 5 cycle

6.2、 Failure Judgment Criterion

After the above-mentioned test

There should not exist conspicuous failure of display quality and appearance.

No degradation of the display readability.

There should not have any abnormality of function.

Document	Specifications	No.	
Section	7.Precaution for Use of LCD Module	Sheet	1/2
		Rev.	0

7.1、 Handling Precautions

- A) The display panel is made of glass. Do not subject it to a mechanical shock by dropping it from a high place, etc.
- B) If the display panel is damaged and the liquid crystal substance inside it leaks out, be sure not to get any in your mouth. If the substance comes into contact with your skin or clothes, promptly wash it off using soap and water.
- C) Do not apply excessive force on the surface of display or the adjoining area of LCD module since this may cause the color tone to vary.
- D) The polarizer covering the display surface of the LCD module is soft and easily scratched. Handle this polarizer carefully.
- E) If the display surface of LCD module cloth with one of the following solvents.
 - . Isopropyl alcohol
 - . Ethyl alcohol
Solvents other than those mentioned above may damage the polarizer.
Especially, do not use water, ketone and aromatic solvents.
- F) When mounting the LCD module, make sure that it is free of twisting, warping and distortion. Distortion has great influence upon display quality. Also keep the shiftiness enough regarding the outer case.
- G) When install the LCD module, do not forcibly pull or bend the I/O cable.
- H) Touching the IC of LCD module may cause abnormal display that cannot recover. Should not touch the IC of LCD module.
- I) Do not disassemble or process the LCD module.
- J) NC terminal should be open. Do not connect anything.
- K) If the logic circuit power is OFF, do not apply the input signals.
- L) To prevent destruction of the elements by static electricity be careful to maintain an optimum work environment.
Be sure to ground the body when handling the LCD module.
Tools required for assembly, such as soldering irons, must be properly grounded.
To reduce the amount of static electricity generated, do not conduct assembly and other work under dry conditions.
The LCD module is coated with a film to protect the display surface. Take care when peeling off this protective film since static electricity may be charged.
- Please handle carefully, because the glass has a sharp edge.

7.2、 Storage Precautions

Take care to minimize corrosion of the electrode. Moisture condensation on a current flow in a high humidity

- A) Environment accelerates corrosion of the electrodes.
- B) When storing the LCD module, avoid exposure to direct sunlight or to the light of fluorescent lamps. Keep the LCD module in bags designed to prevent static electricity charging under low temperature / normal humidity conditions (avoid high temperature / high humidity and low temperature below 0°C).

Whenever possible, the LCD module should be stored in the same conditions in which they were shipped from our company.

Document	Specifications	No.	
Section	7.Precaution for Use of LCD Module	Sheet	2/2
		Rev.	0

7.3、 Design Precautions

- A) The absolute maximum ratings represent the rated value beyond which LCD module can not exceed. When the LCD module are used in excess of this fated value, their operating characteristics may be adversely affected.
- B) To prevent the occurrence of erroneous operation caused by the noise, attention must be paid to satisfy VIL, VIH specification values, including taking the precaution of using signal cables that are short.
- C) The liquid crystal display exhibits temperature dependency characteristics. Since recognition of the display becomes difficult when the LCD is used out of its designated operating temperature range, be sure to use the LCD within this range.
- D) We recommend that power supply lines (VDD) have over-current protection line.(Fuse etc.)
- E) Sufficiently notice the mutual noise interference occurred by peripheral devices.
- F) To cope with EMI, take measures basically on outputting side.

When fixing LCD module, which is consisted of glass panel, TCP fixes it at plastic case side. In case PCB is fixed, there is the possibility that the disconnection is occurred by somewhat stress.

7.4、 Other

- A) Liquid crystal solidify under low temperatures (below the storage temperature range) leading to defective orientation or the generation of air bubbles.
Air bubbles may also be generated if the LCD module is subjected to a strong shock at a low temperature.
- B) If the LCD module has been operating for a long time showing the same display pattern, the display pattern may remain on the screen as ghost images and a slight contract irregularity may also appear. A normal operating status can be regained by suspending use for some time it should be noted that this phenomenon does not adversely affect performance reliability.
- C) To minimize the performance degradation of the LCD modules resulting from destruction caused sections by static electricity, etc, take care to avoid touching the following sections when handing the module.
- Terminal electrode sections

Document	Specifications	No.	
Section	8. Visual Inspection	Sheet	1/1
		Rev.	0

The module should operate:

- all points should be activated (On/OFF) independently.
- Each physical point location should correspond to each software point location.

No color defect inside visible area.

No progressing glass crack.

8.1、Air bubbles

Air bubbles between glass and polarizer.

Size Diam. (mm)	Acceptable Number In Viewing Area
Diam. 0.2	2 *1
0.3<diam.	0

*1: The distance between two air bubbles is over 30mm.

8.2、Black/White Spots

Blemish and foreign substances: $\phi = (a+b)/2$, with $b \geq 2a$

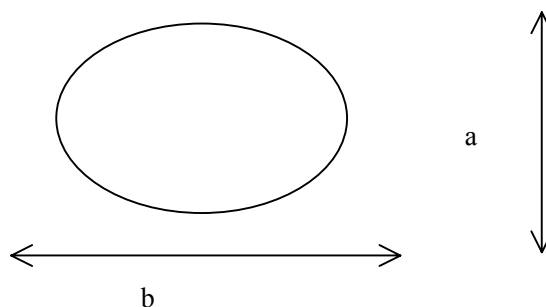

Size (mm)	Acceptable Number In Viewing Area
$\phi \leq 0.15$	Ignore
$0.15 < \phi \leq 0.3$	2 *1
$0.3 < \phi$	0

*1: The distance between two spots is over 30mm.

8.3、Black/White Lines

Blemish, foreign substances and scratch:

Length L (mm)	Width W (mm)	Acceptable Number In Viewing Area
L ≤ 5	W ≤ 0.05	Ignore
L > 5	W ≤ 0.05	0
L ≤ 3	0.05 < W ≤ 0.1	3
L > 3	W > 0.1	0