

EMI/EMC FILTER

ES3 SERIES



FEATURES

- Suitable for the products that must conform to FCC, FTZ.
- Good shield effect by using metal case.
- Excellent filtering characteristics for both differential mode and common mode.
- Two stage for excellent filtering characteristics.
- Epoxy molded for reliability.
- Bidirectional structure effective for both noise from outside and internally generated.

APPLICATIONS

- Digital equipments.
- Measuring and testing instruments.
- Communication equipments.
- For equipments requiring very high noise attenuation.

SPECIFICATIONS

Model	Rated Voltage (AC,DC)	Rated Current	Temperature Rise	Operating Temperature
ES3-F03-14(7)	250V	3A	30°C max.	-25°C to +85°C Including temperature rise ※ Fig.1
ES3-F05-14(7)	250V	5A	30°C max.	

Note : All types are designed to meet the requirement of UL 1283, CSA 22.2, IEC 133200 : 1999 K60939
 Test Voltage : 1500V AC one minute, line to earth.
 Insulation Resistance : 300Mohm min. at 500VDC
 Leakage Current : 0.7mA max.
 Voltage Drop : 1V max. at rated current.
 Discharge time : 0.4 sec. max.
 Weight : 170g.

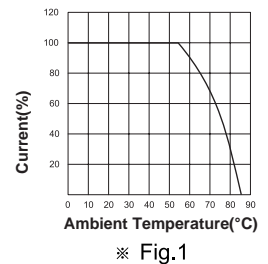

■ Model Number Construction

ES3	F	03	1	4
Series Description	Input/Output Terminal style F : Faston Tab #250	Current Rating:AC rms 03:3 amp 05:5 amp	Line-Line Cap. Value 1 : 3 × 0.1 μF	Line-Gnd. Cap. Value 4 : 2 × 4700 pF 7 : 2 × 3300 pF + 2 × 1000 pF (See Circuit Diagram next page)

Shapes and Dimensions

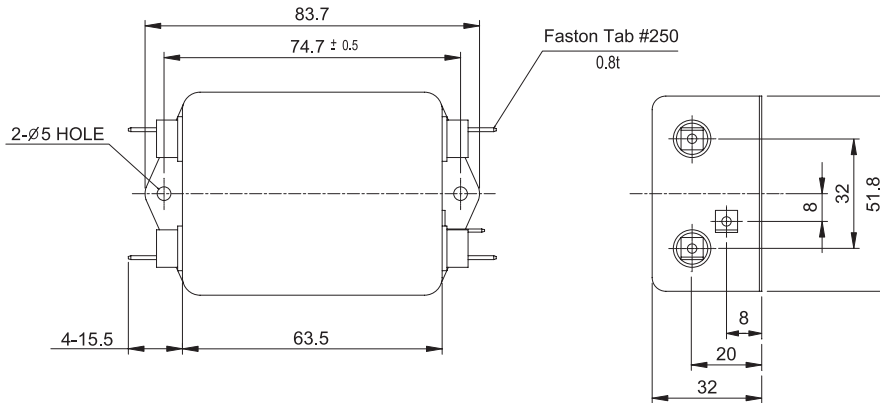

* General tolerance : ± 1.0
 * Unit : mm
 * Metal Case

Attenuation Characteristics

● Common Mode

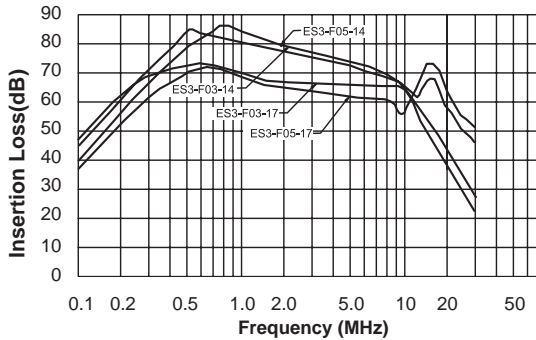

● Differential Mode

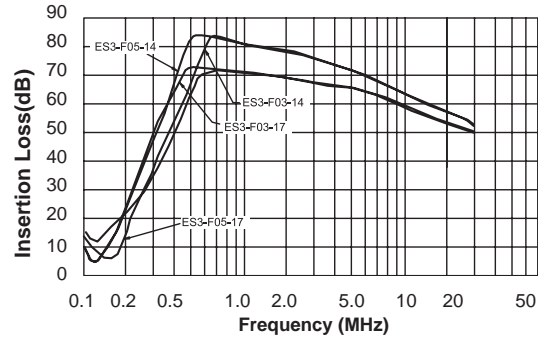

● Circuit Diagram

ES3-F**-14 type

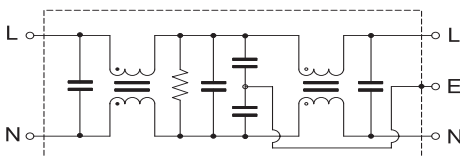

ES3-F**-17 type

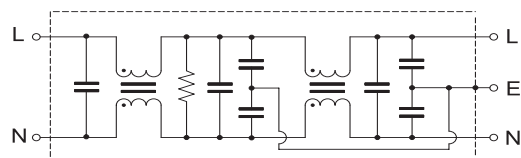

● Measurement configuration

