Helixeon - Color Series



Helixeon, a solid-state lighting device, provides high luminous flux output with high efficiency. Helixeon is encapsulated in silicone by molding technology. Also, Helixeon is capable of standard lead free solder reflow process. The standard color product line includes red, green, blue, amber, cyan, and etc.

Features

- High luminous flux output
- Long life operation
- Instant response
- RoHS certification
- Superior ESD protection
- Silicone molding lens

Application

- Decoration lighting
- Architectural lighting
- Stage lighting
- General lighting



HELIO Optoelectronics Corp.

Product Nomenclature

HM **HP** - **E** **1** **L** **R**
 X1 X2 X3 X4 X5 X6

X1		X2		X3		X4	
Item		Mode		Heat sink		Power	
Code	Type	Code	Type	Code	Type	Code	Type
HM	Molding	HP	High power	E	Emitter	1	1W

X5		X6	
Lens		Color	
Code	Type	Code	Type
L	Lambertian	R	Red
H	Lambertian II	A	Amber
F	Focusing	G	Green
B	Batwing	B	Blue
		C	Cyan

Circuit Diagram of Helixeon Emitter

Color	Part number	Circuit diagram
Red	HMHP-E1LR 、 HMHP-E1FR HMHP-E1BR 、 HMHP-E1HR	
Amber	HMHP-E1LA 、 HMHP-E1FA HMHP-E1BA 、 HMHP-E1HA	
Green	HMHP-E1LG 、 HMHP-E1FG HMHP-E1BG 、 HMHP-E1HG	
Blue	HMHP-E1LB 、 HMHP-E1FB HMHP-E1BB 、 HMHP-E1HB	
Cyan	HMHP-E1LC	

The information contained herein is the exclusive property of HELIO and shall not be distributed reproduced, or disclosed in whole or in part without prior written permission of HELIO.

HELIO Optoelectronics Corp.

■ Package Dimensions

SMT Lead Form

Lambertian

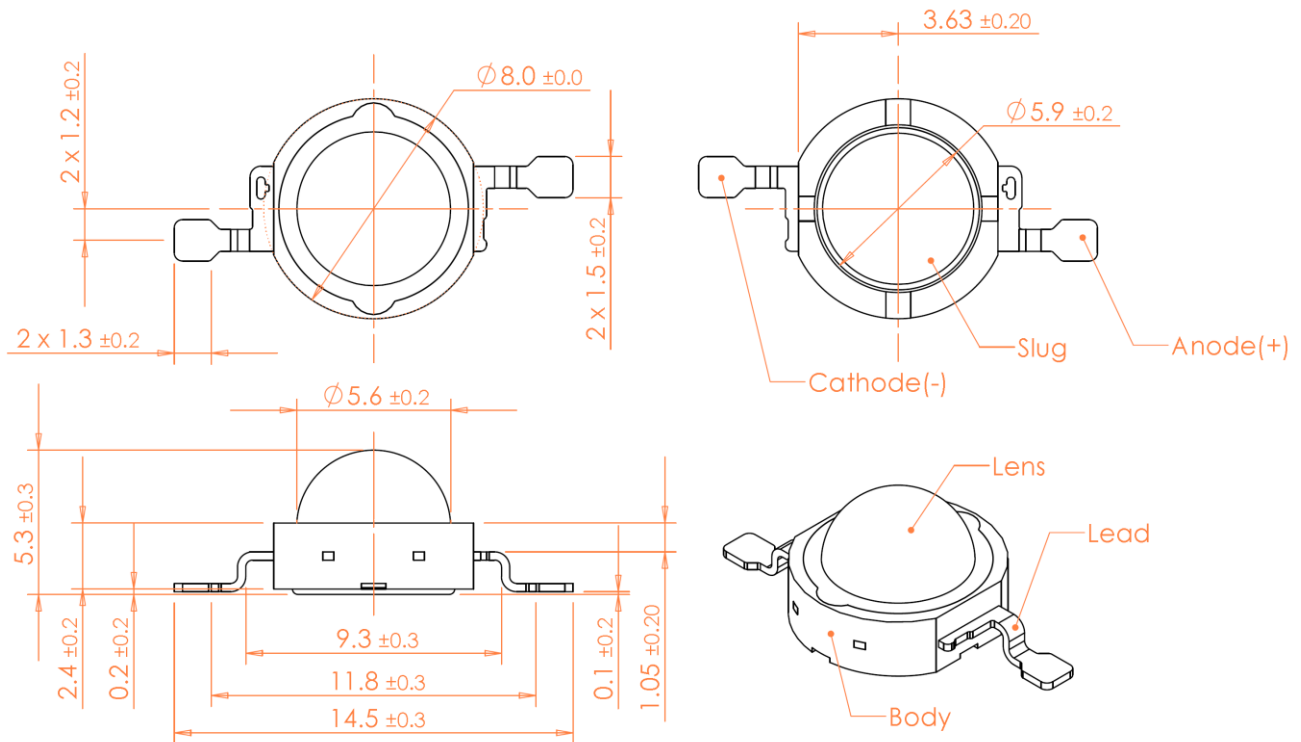

Note:

1. The anode side of the device is denoted by a hole in the lead frame.
2. Electrical insulation between the case and the board is required. The slug of the device is no electrically neutral.
3. Drawings are not to scale.
4. All dimensions are all in millimeter.
5. All dimensions without tolerance are for reference only.
6. Specifications are subject to change without notice.

The information contained herein is the exclusive property of HELIO and shall not be distributed reproduced, or disclosed in whole or in part without prior written permission of HELIO.

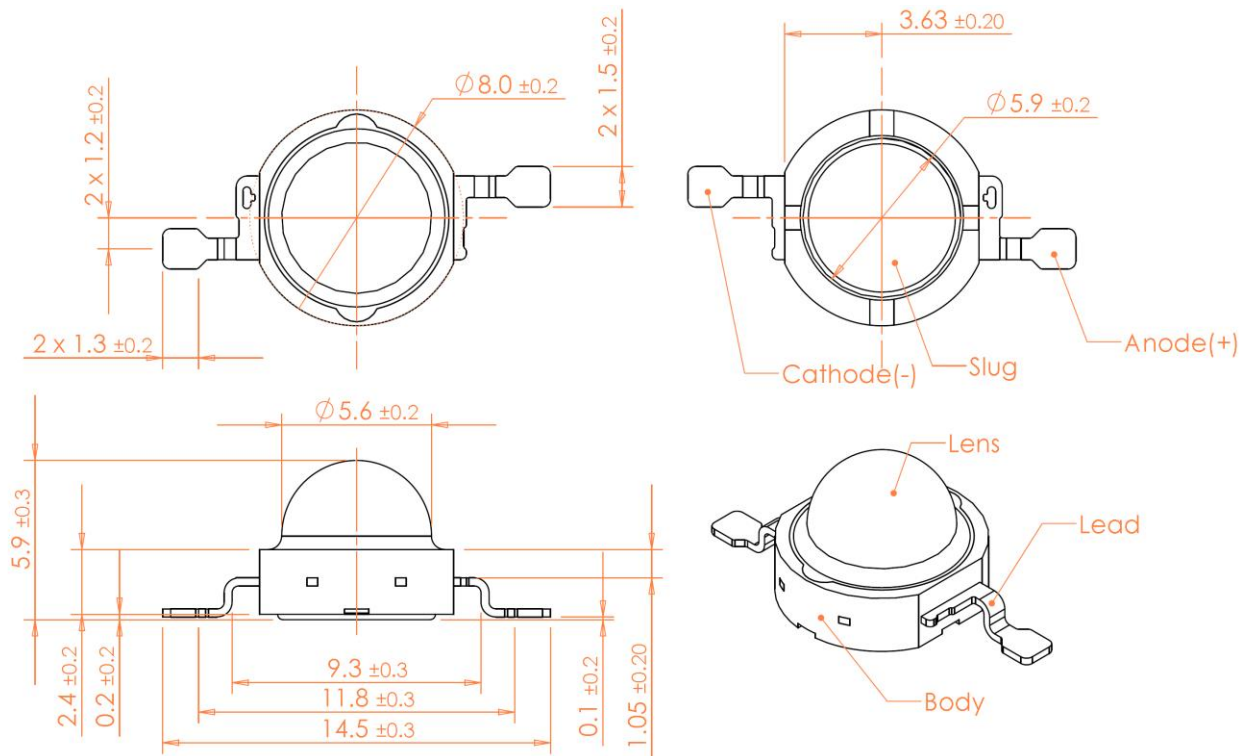
HELIO Optoelectronics Corp.**Lambertian II****Note:**

1. The anode side of the device is denoted by a hole in the lead frame.
2. Electrical insulation between the case and the board is required. The slug of the device is no electrically neutral.
3. Drawings are not to scale.
4. All dimensions are all in millimeter.
5. All dimensions without tolerance are for reference only.
6. Specifications are subject to change without notice.

The information contained herein is the exclusive property of HELIO and shall not be distributed reproduced, or disclosed in whole or in part without prior written permission of HELIO.

Batwing

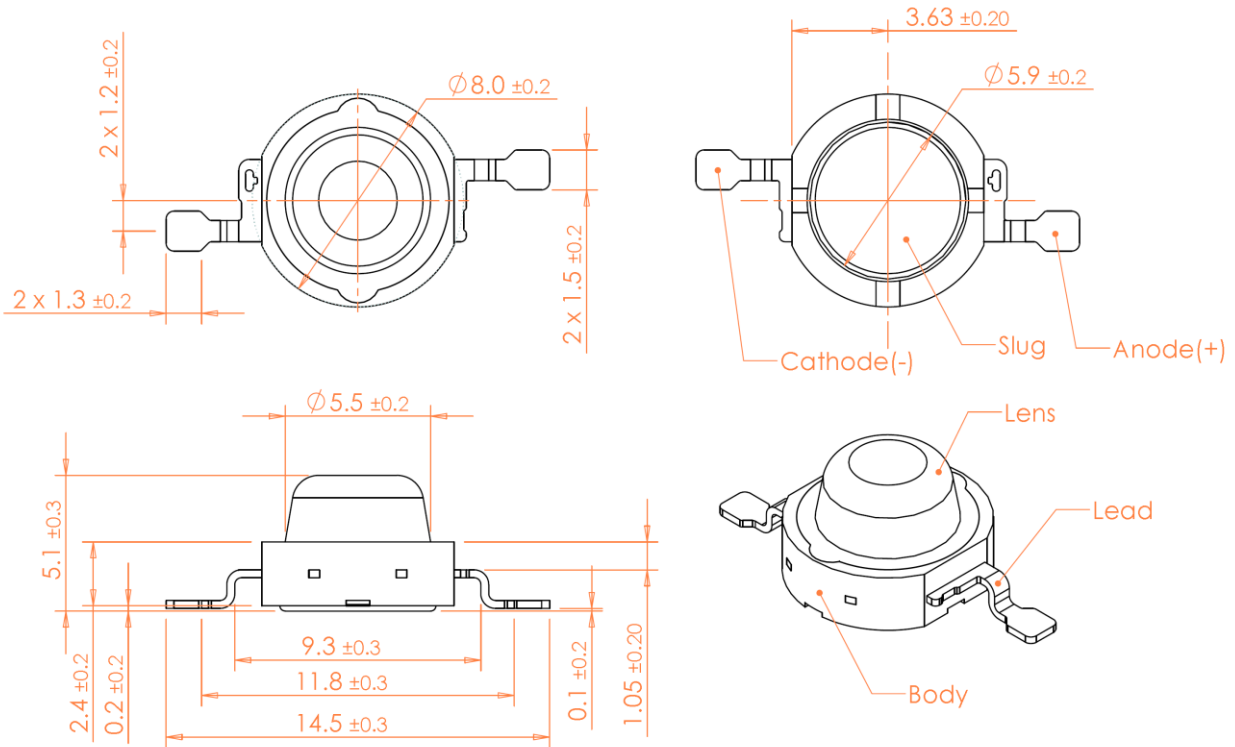

Note:

1. The anode side of the device is denoted by a hole in the lead frame.
2. Electrical insulation between the case and the board is required. The slug of the device is no electrically neutral.
3. Drawings are not to scale.
4. All dimensions are all in millimeter.
5. All dimensions without tolerance are for reference only.
6. Specifications are subject to change without notice.

Focusing

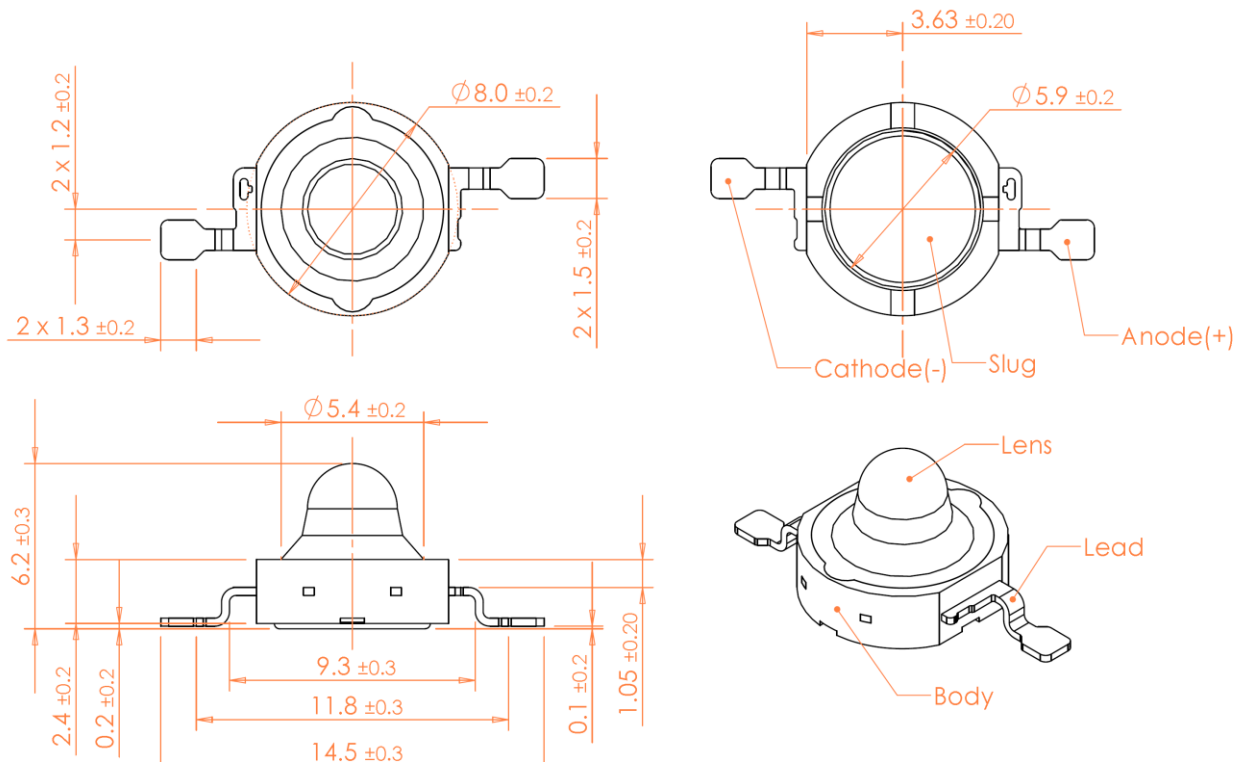

Note:

1. The anode side of the device is denoted by a hole in the lead frame.
2. Electrical insulation between the case and the board is required. The slug of the device is no electrically neutral.
3. Drawings are not to scale.
4. All dimensions are all in millimeter.
5. All dimensions without tolerance are for reference only.
6. Specifications are subject to change without notice.

*HELIO Optoelectronics Corp.***■ Characteristics for Helixeon emitter****HMHP-E1LR、HMHP-E1FR、HMHP-E1BR、HMHP-E1HR**Characteristics at $I_f = 350\text{mA}$ ($T_a = 25^\circ\text{C}$):

Parameter	Symbol	Value			Unit
		Min	Typical	Max	
Luminous flux ⁽¹⁾	$\Phi_v^{(2)}$	45	50	--	lm
Dominant Wavelength ⁽³⁾	Wd	610	--	630	nm
View angle (Lambertian)	$2\Theta_{1/2}$	--	150	--	degree
View angle (Lambertian II)		--	140	--	
View angle (Focusing)		--	75	--	
View angle (Batwing)		--	140	--	
Forward Voltage ⁽⁴⁾	V_F	2.0	--	3.0	V
Power dissipation	P_D	0.7	--	1.05	W

HMHP-E1LA、HMHP-E1FA、HMHP-E1BA、HMHP-E1HACharacteristics at $I_f = 350\text{mA}$ ($T_a = 25^\circ\text{C}$):

Parameter	Symbol	Value			Unit
		Min	Typical	Max	
Luminous flux ⁽¹⁾	$\Phi_v^{(2)}$	45	50	--	lm
Dominant Wavelength ⁽³⁾	Wd	585	--	595	nm
View angle (Lambertian)	$2\Theta_{1/2}$	--	150	--	degree
View angle (Lambertian II)		--	140	--	
View angle (Focusing)		--	75	--	
View angle (Batwing)		--	140	--	
Forward Voltage ⁽⁴⁾	V_F	2.0	--	3.0	V
Power dissipation	P_D	0.7	--	1.05	W

The information contained herein is the exclusive property of HELIO and shall not be distributed reproduced, or disclosed in whole or in part without prior written permission of HELIO.



HELIO Optoelectronics Corp.

HMHP-E1LG、HMHP-E1FG、HMHP-E1BG、HMHP-E1HG

Characteristics at $I_F = 350\text{mA}$ ($T_a=25^\circ\text{C}$):

Parameter	Symbol	Value			Unit
		Min	Typical	Max	
Luminous flux ⁽¹⁾	$\Phi_v^{(2)}$	80	90	--	lm
Dominant Wavelength ⁽³⁾	Wd	515	--	535	nm
View angle (Lambertian)	$2\Theta_{1/2}$	--	165	--	degree
View angle (Lambertian II)		--	150	--	
View angle (Focusing)		--	70	--	
View angle (Batwing)		--	140	--	
Forward Voltage ⁽⁴⁾	V_F	3.0	--	4.0	V
Power dissipation	P_D	1.05	--	1.4	W

HMHP-E1LB、HMHP-E1FB、HMHP-E1BB、HMHP-E1HB

Characteristics at $I_F = 350\text{mA}$ ($T_a=25^\circ\text{C}$):

Parameter	Symbol	Value			Unit
		Min	Typical	Max	
Luminous flux ⁽¹⁾	$\Phi_v^{(2)}$	20	23	--	lm
Dominant Wavelength ⁽³⁾	Wd	460	--	475	nm
View angle (Lambertian)	$2\Theta_{1/2}$	--	165	--	degree
View angle (Lambertian II)		--	150	--	
View angle (Focusing)		--	70	--	
View angle (Batwing)		--	140	--	
Forward Voltage ⁽⁴⁾	V_F	3.0	--	4.0	V
Power dissipation	P_D	1.05	--	1.4	W

The information contained herein is the exclusive property of HELIO and shall not be distributed reproduced, or disclosed in whole or in part without prior written permission of HELIO.



HELIO Optoelectronics Corp.

HMHP-E1LC

Characteristics at $I_F = 350\text{mA}$ ($T_a=25^\circ\text{C}$):

Parameter	Symbol	Value			Unit
		Min	Typical	Max	
Luminous flux ⁽¹⁾	Φ_v ⁽²⁾	67	77	--	lm
Dominant Wavelength ⁽³⁾	Wd	495	--	510	nm
View angle	$2\Theta_{1/2}$	--	165	--	degree
Forward Voltage ⁽⁴⁾	V_F	3.0	--	4.0	V
Power dissipation	P_D	1.05	--	1.4	W

Note:

1. The typical luminous flux of Helixeon will be upgraded per season.
2. Φ_v , minimum luminous flux performance guaranteed within published operating conditions. HELIO maintains a tolerance of $\pm 10\%$ luminous flux measurements.
3. Dominant wavelength is derived from the CIE1931 chromaticity diagram and represents the perceived color. The tester tolerance of dominant wavelength is $\pm 1\text{nm}$.
4. HELIO maintains a tolerance of $\pm 0.06\text{V}$ on forward voltage measurements.



HELIO Optoelectronics Corp.

■ Absolute Maximum Ratings

Parameter	1W
Peak Forward Current (1/10 Duty Cycle at 1KHz)	500mA
Continuous Forward Current	350mA
LED Junction Temperature	120°C
Operation Temperature	-40°C ~+105°C
Storage Temperature	-40°C ~+120°C
Soldering Temperature	JEDEC 020c 260°C
Allowable Reflow Cycles	3 Times
ESD Sensitivity ⁽¹⁾	> 8,000V Human Body Model (HBM) Class 2 JESD22-A114-B
Reverse Voltage (V)	not designed for reverse operation

Note:

1. It is included the zener chip to protect the product from ESD.



HELIO Optoelectronics Corp.

■ Bin Code

Color	Luminous flux (lm)	Rank (BIN)	Wavelength (nm)	Rank (BIN)
Red	30.6 - 39.8	Q0	610 - 620	A0
	39.8 - 51.7	R0	620 - 630	B0
	51.7 - 67.2	S0	630 - 640	C0
Amber	30.6 - 39.8	Q0	585 - 587.5	A0
	39.8 - 51.7	R0	587.5 - 590	B0
	51.7 - 67.2	S0	590 - 592.5	C0
			592.5 - 595	D0
Green	51.7 - 67.2	S0	515 - 520	B0
	67.2 - 87.4	T0	520 - 525	C0
	87.4 - 113.6	U0	525 - 530	D0
	113.6 - 147.7	V0	530 - 535	E0
			535 - 540	F0
Blue	13.9 - 18.1	M0	460 - 465	E0
	18.1 - 23.5	N0	465 - 470	F0
	23.5 - 30.6	P0	470 - 475	G0
Cyan	39.8 - 51.7	R0	490 - 495	A0
	51.7 - 67.2	S0	495 - 500	B0
			500 - 505	C0

The information contained herein is the exclusive property of HELIO and shall not be distributed reproduced, or disclosed in whole or in part without prior written permission of HELIO.



HELIO Optoelectronics Corp.

Optical & Electrical characteristics

Wavelength Characteristics

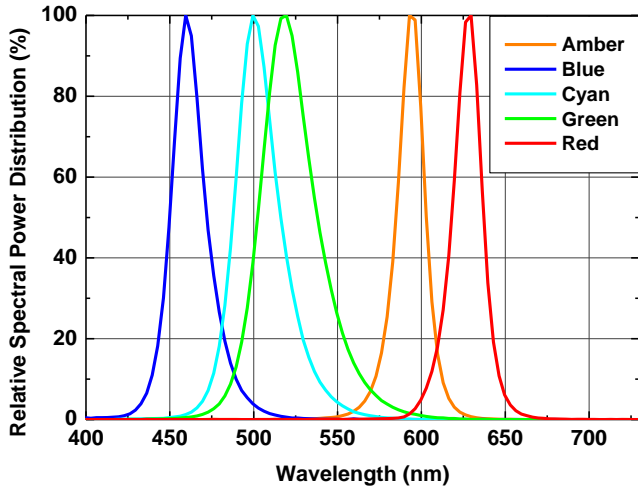

Forward Voltage vs Forward Current

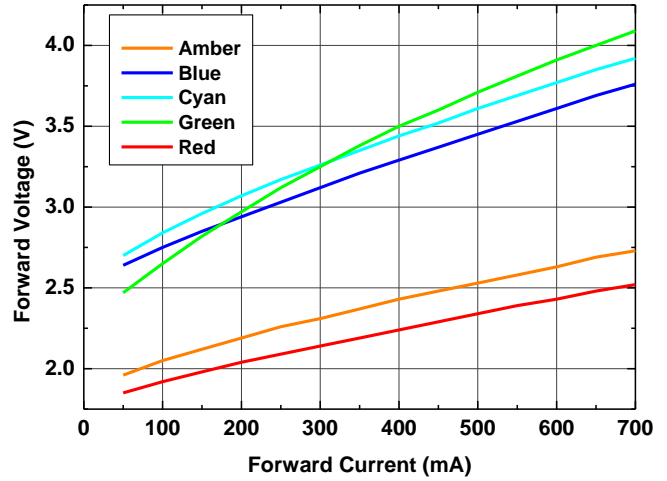

Operating Current & Ambient Temperature

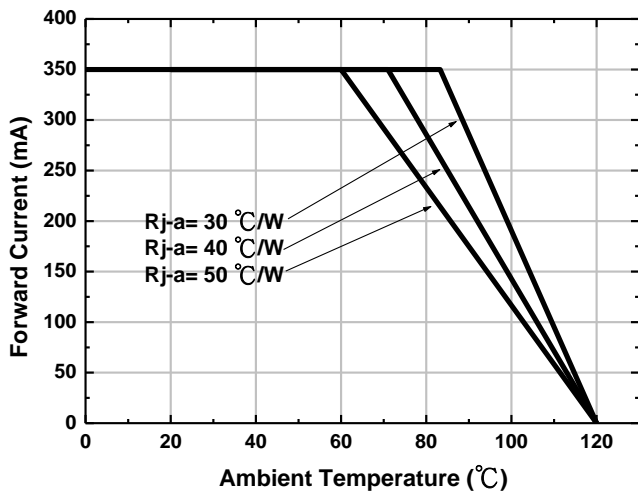

Typical Light Output Characteristics over Forward Current

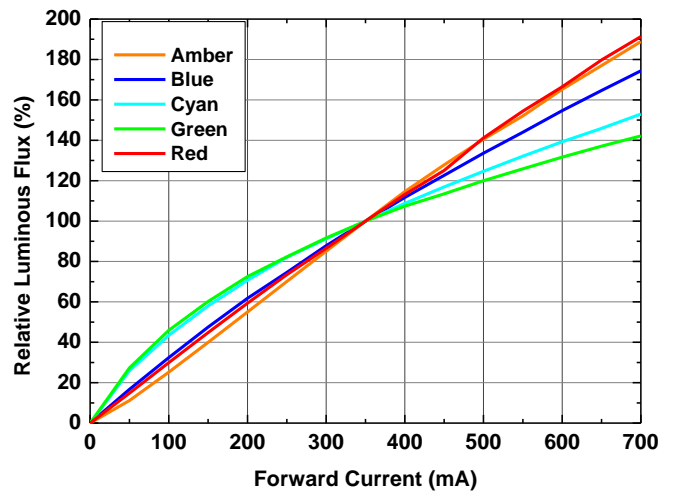

The information contained herein is the exclusive property of HELIO and shall not be distributed reproduced, or disclosed in whole or in part without prior written permission of HELIO.

HELIO Optoelectronics Corp.

■ Typical Polar Radiation Pattern

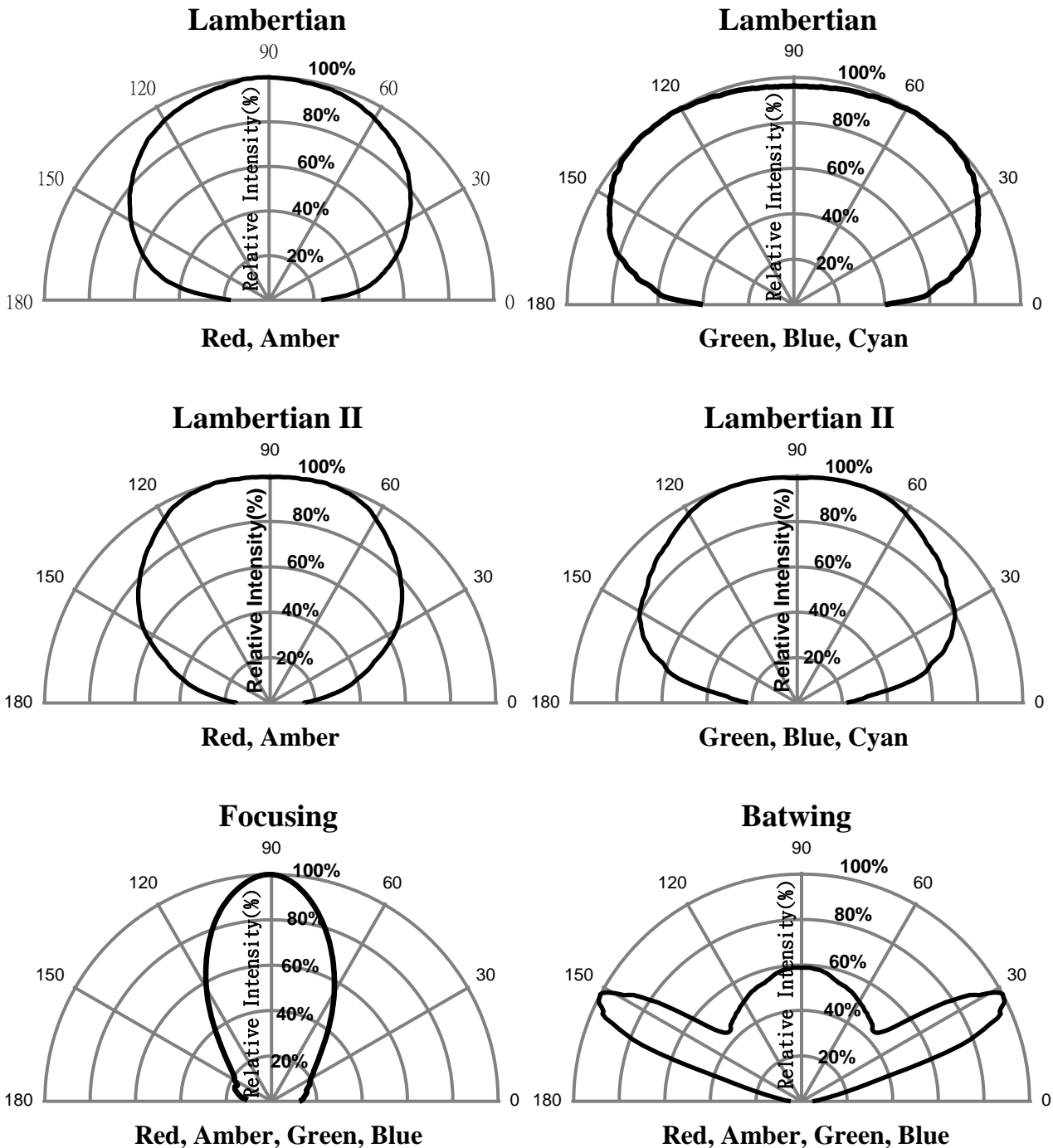

The information contained herein is the exclusive property of HELIO and shall not be distributed reproduced, or disclosed in whole or in part without prior written permission of HELIO.

HELIO Optoelectronics Corp.

■ Storage

- Do not open the moisture proof bag before the devices are ready to use.
- Before the package is opened, LEDs should be stored at temperatures less than 30°C and humidity less than 50%.
- After the package is opened, LEDs should be stored at temperatures less than 30°C and humidity less than 30%.
- LEDs should be used within 168 hours (7 days) after the package is opened.
- Before using LEDs, baking treatment should be implemented based on the following conditions: pre-curing at 60±5°C for 6 hours.

■ Handling Precaution

The softness and dust affinity of silicone molding lens constrain the handling of LED. Thus, some handling indications of HELIXEON emitters are presented for possible damage prevention and excellent reliability.

- Avoid leaving fingerprints or scratches (by sharp tools) on the silicone resin parts.
- Do not force over 2000gf impact or pressure on the silicone molding lens.
- The LEDs should only be picked up by making contact with the sides of the LED body.
- When populating in SMT production, the pick-and-place nozzle must not place excessive pressure on the silicone molding lens.



The information contained herein is the exclusive property of HELIO and shall not be distributed reproduced, or disclosed in whole or in part without prior written permission of HELIO.

HELIO Optoelectronics Corp.

■ Solder Reflow Process Parameters

Reflow soldering of Helixeon emitters requires effective control of heating and cooling. Both the rate of heating and cooling and the absolute temperatures reached are critical in assuring the formation of a reliable solder joint while avoiding damage to the emitter during the reflow process. The recommended temperature profile of solder reflow process is shown below in the figure.

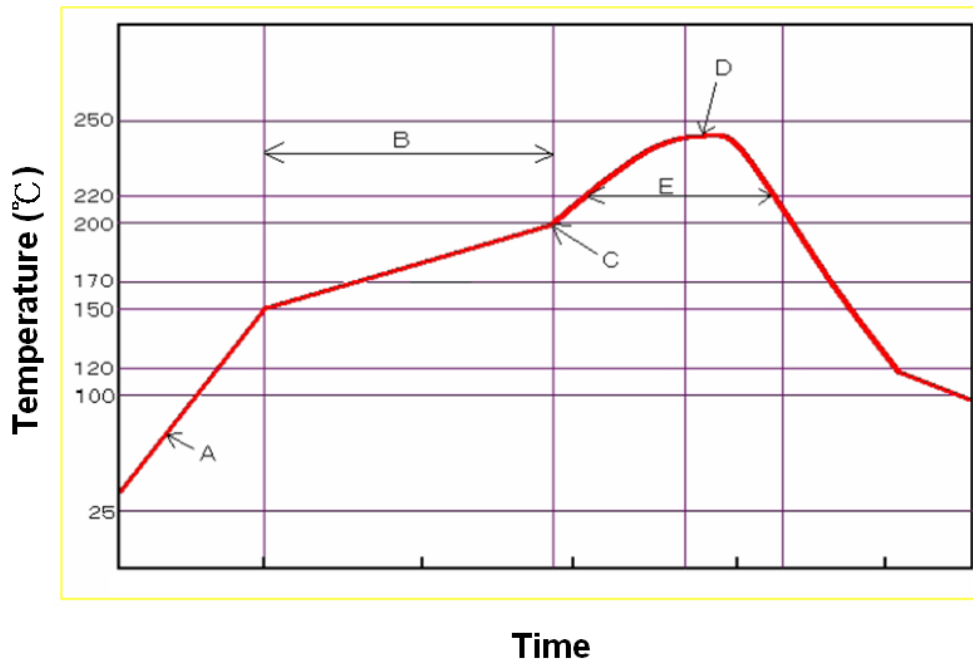

1. Preheat
 - Set the temperature rising speed A at a rate of 2~4°C/s. Careful about rapid temperature rise in preheat zone as it may cause excessive slumping of the solder paste.
 - Appropriate preheat time B will be from 60 to 180 seconds. If the preheat is insufficient, rather large solder balls tend to be generated. Conversely, if performed excessively, fine balls and large balls will generate in clusters at a time.
 - Appropriate preheat ending temperature C will be from 180 to 200°C. If the temperature is too low, non-melting tends to be caused in the area with large heat capacity after reflow.
2. Heating
 - Careful about sudden rise in temperature as it may worsen the slump of solder paste.
 - Set the peak temperature D in the range from 230 to 240°C.
 - Adjust the melting time that the time over 220°C, E, will be from 30 to 90 seconds.
3. Cooling
 - Careful about slow cooling as it may cause the positional shift of parts and decline in joining strength at times.

The information contained herein is the exclusive property of HELIO and shall not be distributed reproduced, or disclosed in whole or in part without prior written permission of HELIO.



HELIO Optoelectronics Corp.

■ Reliability Test List

Test Item	Standard Test Method	Test Conditions	Note	Number of Damaged
Resistance to soldering heat (reflow soldering)	JEITA ED-4701 300 301	Ta=260°C, 10sec. (Pre treatment 25°C,70%,168hrs.)	2 times	0/10
Solderability (reflow soldering)	JEITA ED-4701 300 303	Tsld=215±5°C, 3sec. (Lead Solder)	1 time over 95%	0/10
Steady state operating life		Ta=25°C, I _F = 350mA Tested with Helio standard circuit board	1000 hrs.	0/10
Steady state operating life of high humidity heat		60°C, RH=90%, I _F = 350mA Tested with Helio standard circuit board	1000 hrs.	0/10
Temperature cycle	JEITA ED-4701 100 105	-40°C ~ 25°C ~ 100°C ~ 25°C 30min. 5min. 30min. 5min.	100 cycles	0/10
Thermal shock	JEITA ED-4701 300 307	0°C ~ 100°C 15sec. 15sec.	20 cycles	0/10
High temperature storage	JEITA ED-4701 200 201	Ta=100°C	1000 hrs.	0/10
Low temperature storage	JEITA ED-4701 200 202	Ta=-40°C	1000 hrs.	0/10
Vibration		2000 Hz, 2directions	60min.	0/10

Failure Criteria :

- Forward Voltage shift : > 200 mV
- Luminous Flux degradation : > 30 %
- Forward or Reverse Leakage : >10μ A

The information contained herein is the exclusive property of HELIO and shall not be distributed reproduced, or disclosed in whole or in part without prior written permission of HELIO.

HELIO Optoelectronics Corp.

■ Tube Package Specifications

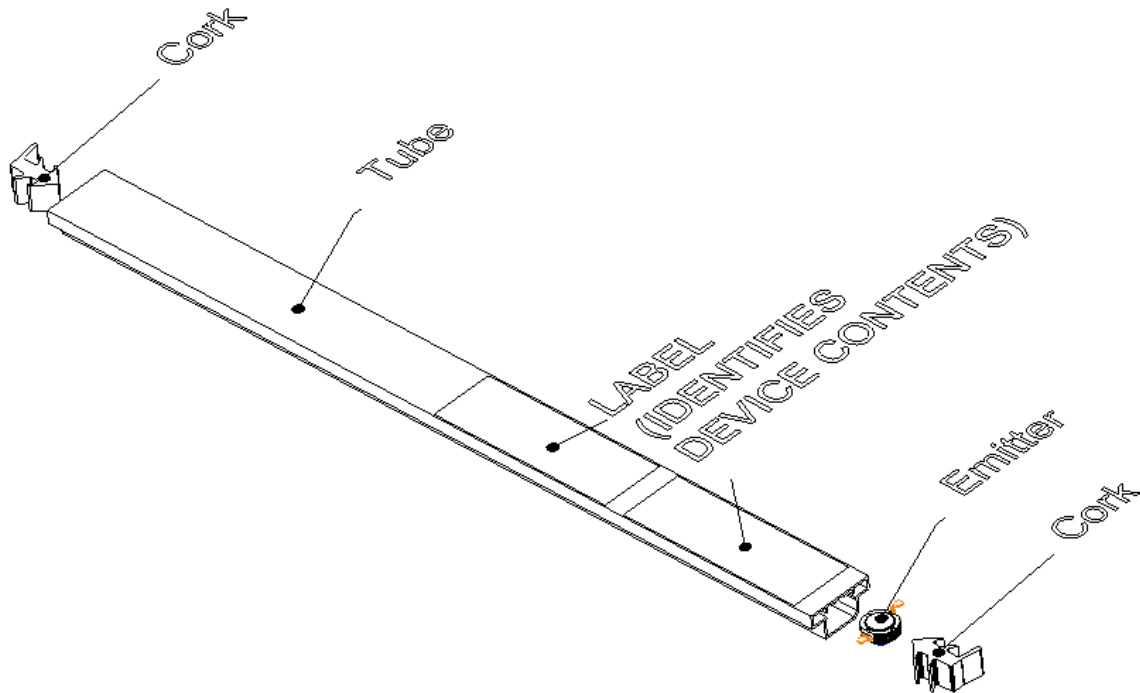

■ TUBE DIMENSIONS

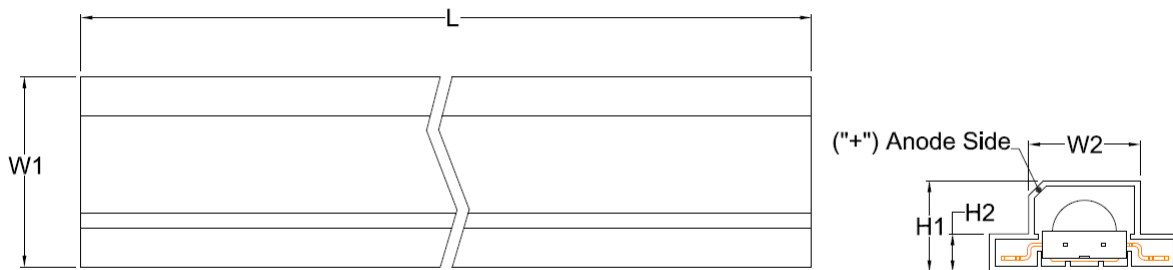

UNIT : mm

W1	W2	H1	H2	L
16.5	9.7	7.9	3.3	420.0
±0.2	±0.2	±0.2	±0.2	±1.0

The information contained herein is the exclusive property of HELIO and shall not be distributed reproduced, or disclosed in whole or in part without prior written permission of HELIO.

HELIO Optoelectronics Corp.

■ Packaging

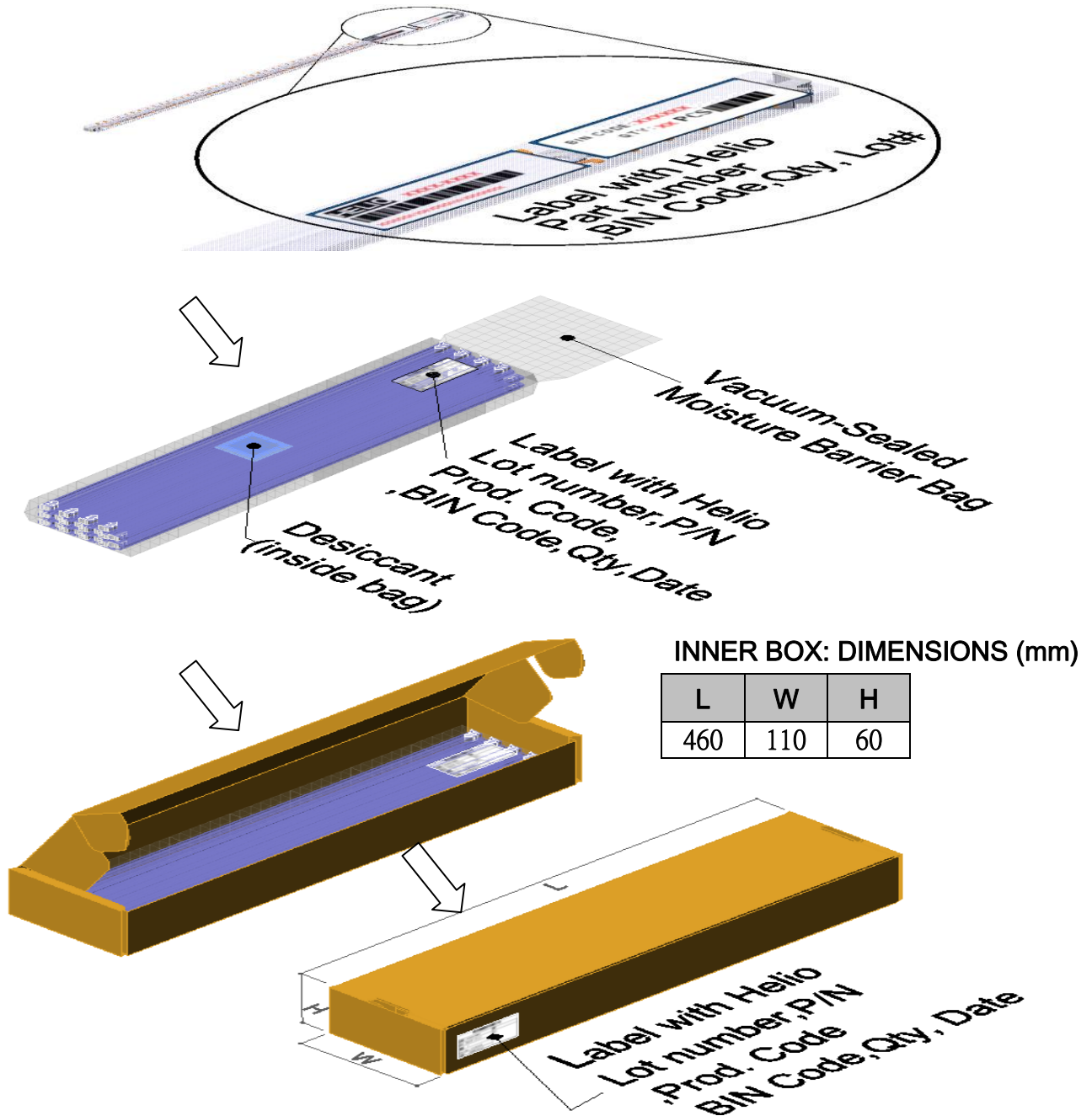

Note:

1. There are 50pcs emitters in a tube.
2. There are 20 tubes in an inner carton.

The information contained herein is the exclusive property of HELIO and shall not be distributed reproduced, or disclosed in whole or in part without prior written permission of HELIO.

HELIO Optoelectronics Corp.

■ Tape-and-Reel Package Specifications

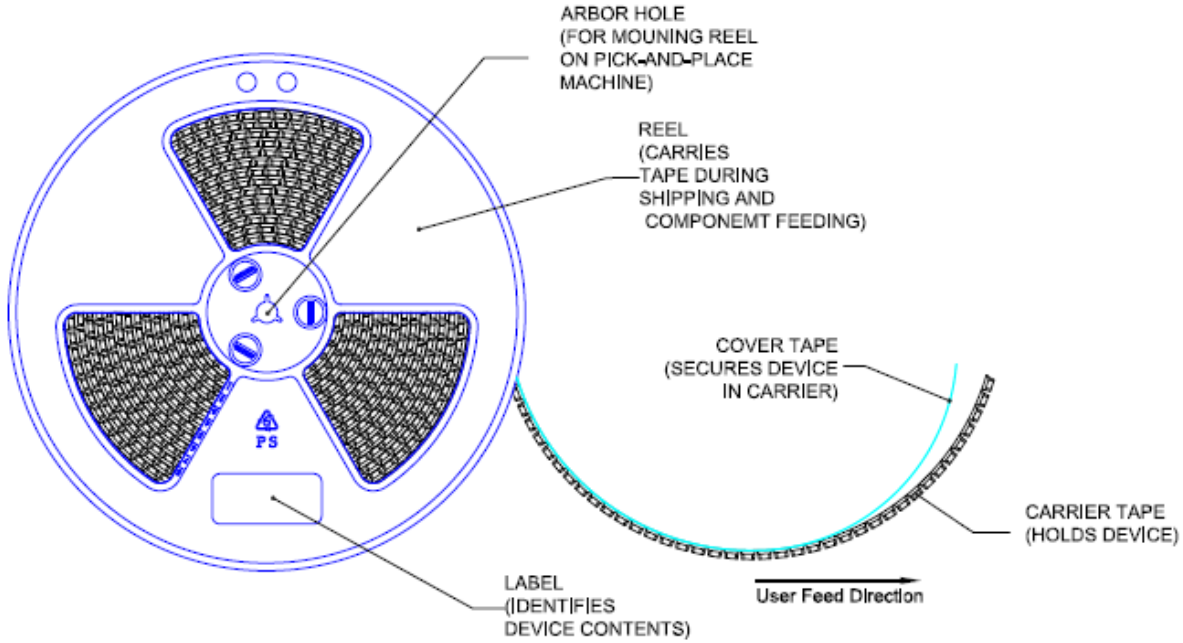

■ CARRIER TAPE DIMENSIONS (2 PINS)

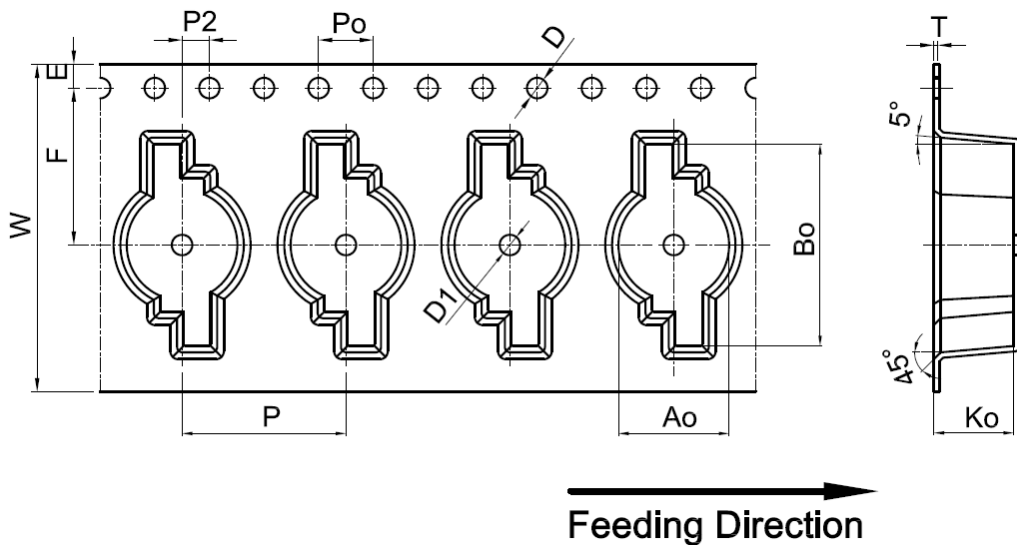

UNIT : mm

W	P	E	F	P2	D	D1	P0	A0	B0	K0	T
24.0	12.0	1.75	11.5	2.0	1.5	1.5	4.0	8.2	14.8	5.85	0.5
±0.3	±0.1	±0.1	±0.1	±0.1	+0.1 -0.0	±0.1	±0.1	±0.1	±0.1	±0.1	±0.05

The information contained herein is the exclusive property of HELIO and shall not be distributed reproduced, or disclosed in whole or in part without prior written permission of HELIO.

HELIO Optoelectronics Corp.

■ REEL DIMENSIONS

UNIT : mm

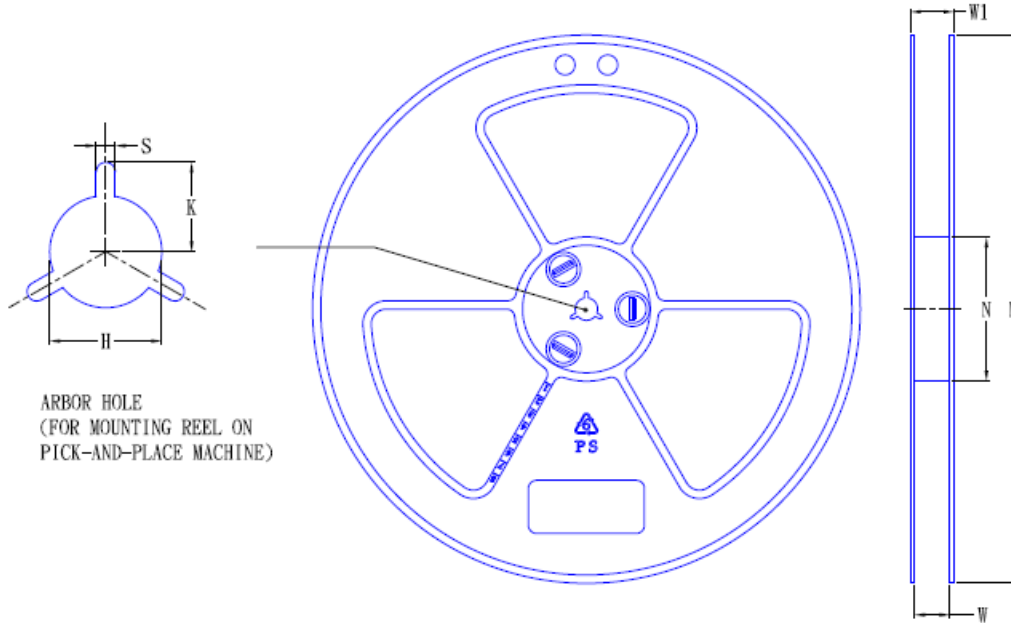

M	N	W	W1	H	K	S
$\phi 380.0$ ± 1.0	$\phi 100.0$ ± 1.0	24.6 ± 0.5	30.6 ± 0.5	$\phi 13.5$ ± 0.5	10.45 ± 0.5	2.5 ± 0.5

■ Leader/Trailer and Orientation(2 PINS)

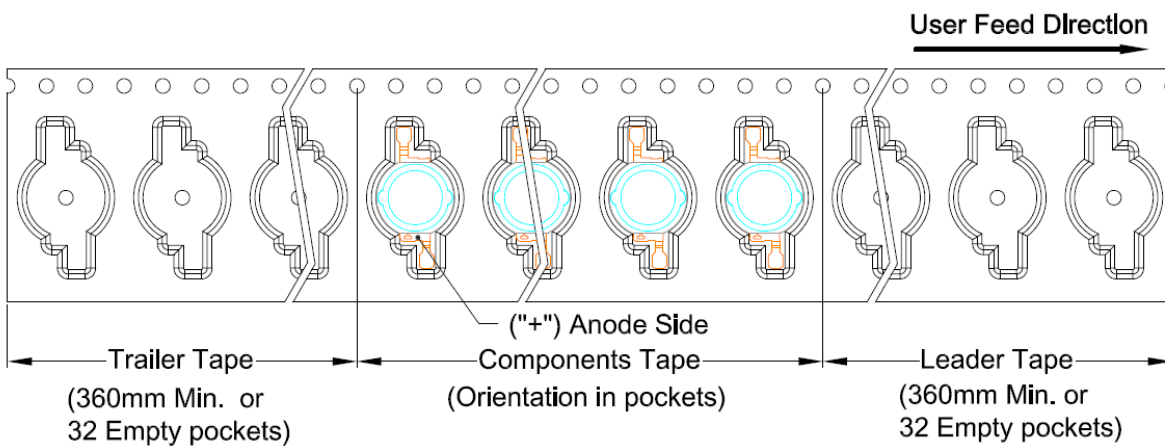

The information contained herein is the exclusive property of HELIO and shall not be distributed reproduced, or disclosed in whole or in part without prior written permission of HELIO.

HELIO Optoelectronics Corp.

■ Packaging

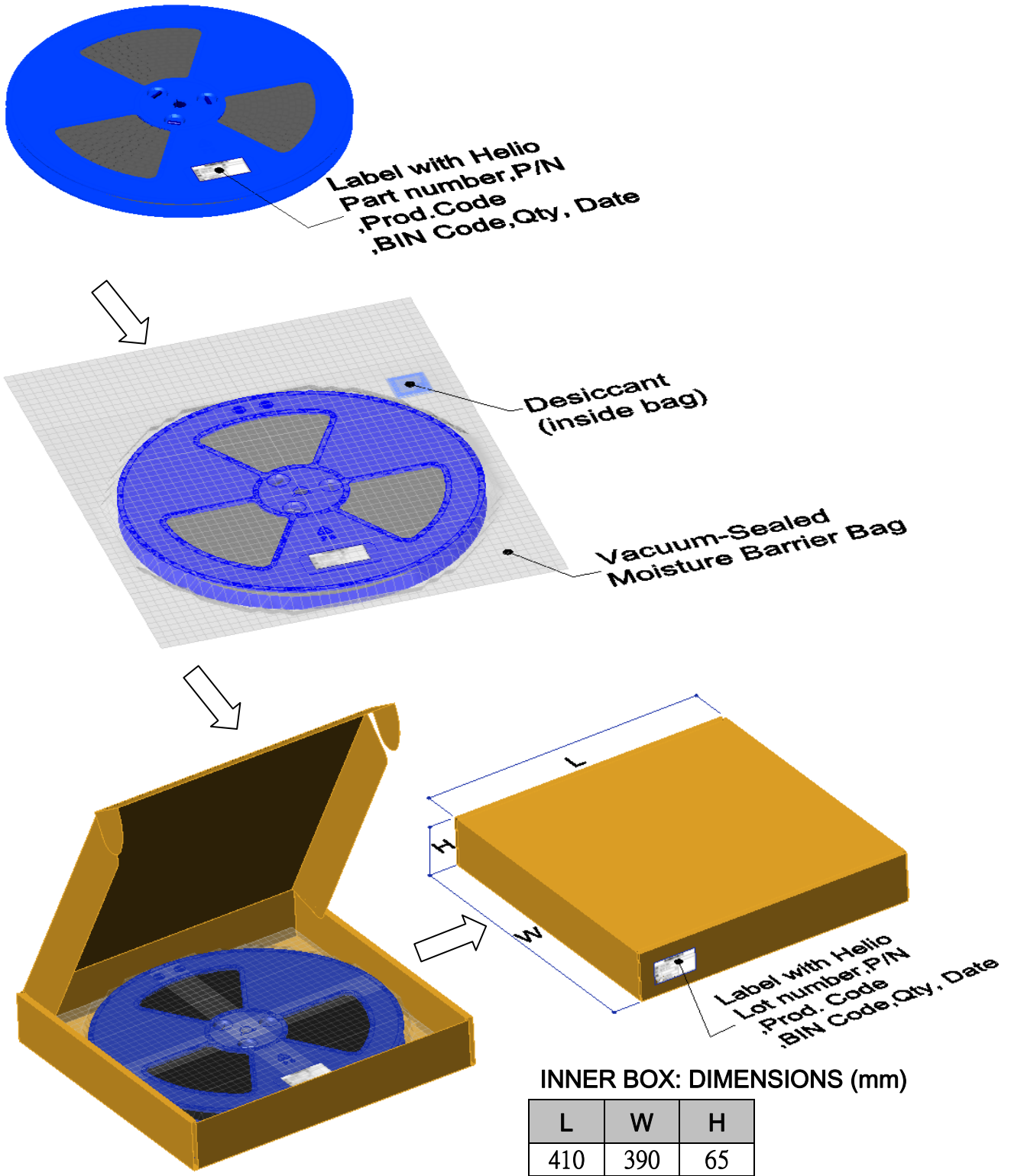

The information contained herein is the exclusive property of HELIO and shall not be distributed reproduced, or disclosed in whole or in part without prior written permission of HELIO.



HELIO Optoelectronics Corp.

■ Bar code Label

Label for Inner Carton

HELIO HELIO Optoelectronics Corp.	
Customer : XXXXXXXXXXXX	QC:
Lot Number : SS2009120100001	
P/N : PLEA-1069	
Prod. Code : HMHP-E1LW	Qty. : 1000 EA
BIN Code : T2W0K0	
	Date : 2009-12-1

Label for Tube & Tray

HELIO HMHP-E1LW
080630323-M1469B-PLEA1069

BIN CODE: T2W0K0
QTY: 50 PCS